



HEARTLAND[®]
APPLIANCES INC.

1050 Fountain St N.
Cambridge, Ontario,
Canada N3H-4R7
Business (519) 650-5501
Fax (519) 650-3773
Toll Free Phone: 1-800-361-1517
Toll Free Fax: 1-800-327-5609

INSTALLATION AND OPERATING INSTRUCTIONS

Save these
instructions
for future use

Note: Please read these instructions thoroughly before attempting to install this unit. Failure to follow installation instructions will result in costly service calls.

NOTE: Clock must be set or your oven will not function!

The oven door thermometer does not sense temperature. It is for aesthetics only and is nonfunctional.

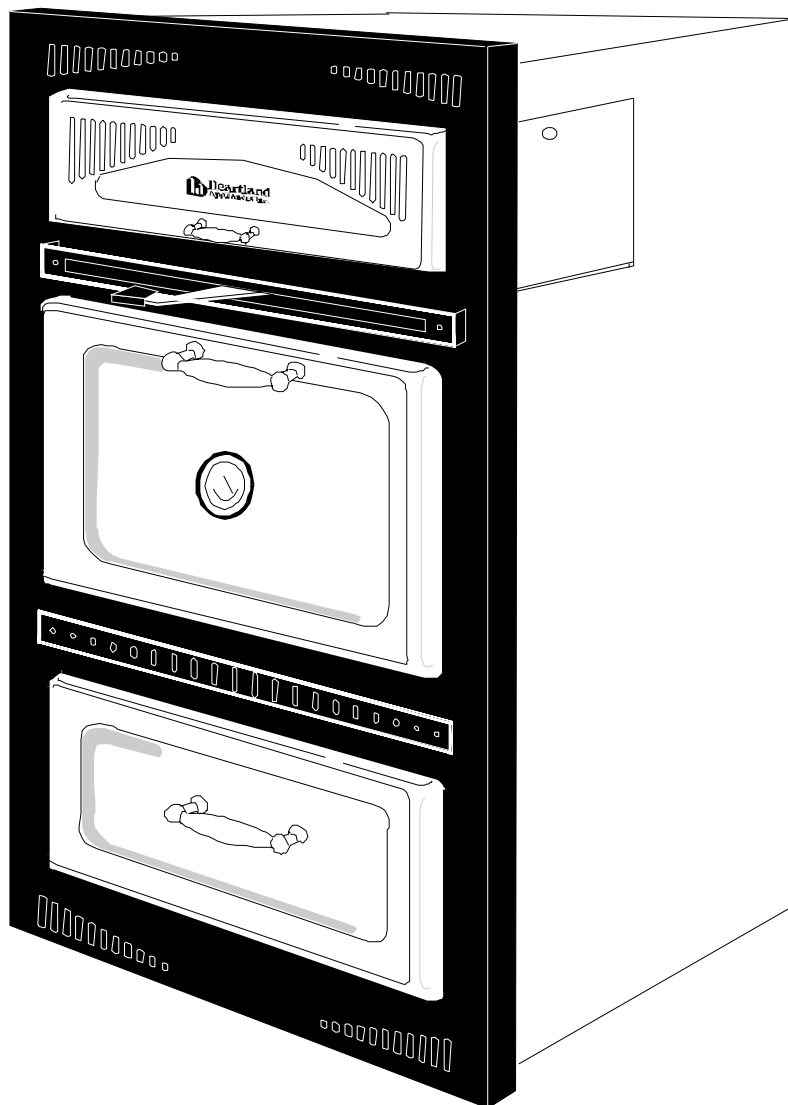

Model 9730



CONVECTION SELF CLEAN AND HALF WALL OVEN

Manual #9716
0042605

ATTENTION INSTALLER: Leave this manual with appliance

© 2005 HEARTLAND APPLIANCES INC.





HEARTLAND[®] APPLIANCES INC.

Electric Self Clean Model 9730 CONSUMER WARRANTY

ENTIRE PRODUCT – LIMITED ONE YEAR WARRANTY

HEARTLAND warrants the replacement or repair of all parts, of this appliance which prove to be defective in material or workmanship, with the exception of the painted or porcelain enamel finish or plated surfaces, for one year from the date of original purchase. Such parts will be repaired or replaced at the option of Heartland without charge, subject to the terms and conditions set out below.

The warranty period against defects in the painted or porcelain enamel finish, or plated surfaces, is 90 days from date of original purchase. **The warranty does not include replacement of oven lamps or filters.**

OVEN ELEMENTS - LIMITED SECOND THROUGH THIRD YEAR WARRANTY

HEARTLAND warrants the oven heating elements against defects in material or workmanship for an additional two years. These parts will be repaired or replaced at the option of Heartland without charge, but you pay for labour and transportation subject to the terms and conditions set out below.

TERMS AND CONDITIONS

1. This warranty applies only for single family domestic use when the appliance has been properly installed according to the instructions supplied by Heartland and is connected to an adequate and proper utility service. Damage due to faulty installation, improper usage and care, abuse, accident, fire, flood, acts of God, commercial, business or rental use, and alteration, or the removal or defacing of the serial plate, cancels all obligations of this warranty. Service during this warranty must be performed by a factory Authorized Service Person.
2. **Warranty applies to product only in the country in which it was purchased.**
3. Heartland is not liable for any claims or damages resulting from any failure of the Cookstove or from service delays beyond their reasonable control.
4. To obtain warranty service, the original purchaser **must** present the original Bill of Sale, Model and Serial number. Components repaired or replaced are warranted through the remainder of the original warranty period only.
5. The warranty does not cover expense involved in making this appliance readily accessible for servicing.
6. This warranty gives you specific legal rights. Additional warranty rights may be provided by law in some areas.
7. Adjustments such as calibrations, levelling, tightening of fasteners, or utility connections normally associated with original installation are the responsibility of the dealer or installer and not that of the Company.

TO ENSURE PROMPT WARRANTY SERVICE, SEND IN YOUR WARRANTY CARD WITHIN 10 DAYS OF PURCHASE.

If further help is needed concerning this warranty, contact:

Customer Service Business (519) 650-5775
1050 Fountain St N. Fax (519) 650-3773
Cambridge, Ontario, Toll Free Telephone 1-800-361-1517
Canada N3H-4R7 Toll Free Fax 1-800-327-5609

PLACE OF PURCHASE _____

DATE OF PURCHASE _____

SERIAL NUMBER _____

MODEL NUMBER _____

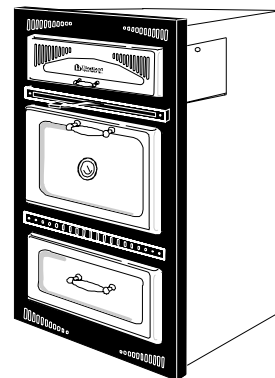

Contents

1. Installation	3	28. Convection Cooking	18
2. Unpacking	3	28. Convection Roasting	18
3. Prepare for Installation	4	29. Roasting Times and Temperature Guide	19
4. Beginning Installation	5	31. Broiling Tips	20
5. Final Installation	6	31. Broiling Guide	21
8. Features	7	32. Baking Times and Temperature Guide	22
8. Dual Oven Control Panel Features	7	33. Poultry Times and Temperature Guide	23
9. Dual Oven Features	8	34. Care and Cleaning	24
10. Important Safety Instructions .	9	35. Porcelain	24
11. Oven Safety	9	36. Nickel Trim	24
12. Self Clean Oven Safety	9	37. Convection Fan Filter	24
14. Operation	10	38. Oven Light Replacement	24
15. Before You Start	10	39. Standard Oven Cleaning	25
16. Getting to Know Your Oven	10	40. Self Clean Oven Cleaning	26
17. Oven Bake Broil Control	11	41. The Broiler Pan	26
18. Clock / Timer Function	12	42. Main Oven Door Removal	27
19. Time of Day Setting	12	43. Lower Oven Door Removal	28
20. Minute Minder	12	44. Interior Oven Rack Removal	29
21. Time Bake	13	45. Rack Supports Removal	29
22. How to Self Clean	14	46. Range Problem Solver	30
23. Time Delay Self Clean	15	47. Oven Thermostat	30
24. How to Select Cooking Methods	17	48. If you still require help—	30
25. Standard Cooking	17	49. Parts Chart / List	31
26. Standard Broiling	17	50. Wiring Diagrams	32
27. Convection	18	51. Products	33

THE OVEN THERMOMETER DOES NOT SENSE TEMPERATURE
The thermometer on the oven door is for aesthetics only and is nonfunctional.

PLEASE READ THESE IMPORTANT SAFETY POINTS

PROPER INSTALLATION - BE SURE YOUR APPLIANCE IS PROPERLY INSTALLED AND GROUNDED BY A QUALIFIED TECHNICIAN.

FOR YOUR SAFETY ... DO NOT STORE OR USE GASOLINE OR OTHER FLAMMABLE VAPOURS OR LIQUIDS IN THE VICINITY OF THIS APPLIANCE.

1. Do not leave children alone. Children should not be left alone or unattended in area where appliance is in use. They should never be allowed to sit or stand on any part of the appliance.
2. Wear proper apparel. Loose fitting or hanging garments should never be worn while using the appliance.
3. User servicing; do not repair or replace any part of the appliance unless specifically recommended in the manual. All other servicing should be referred to a qualified technician.
4. Use only dry pot holders-Moist or damp pot holders on hot surfaces may result in burns from steam. Do not let pot holder touch hot heating elements. Do not use a towel or other bulky cloth.
5. Do not use the oven as a heater.
6. Do not heat unopened glass or metal containers in the oven.
7. Grease accumulation is the cause of many cooking fires. Clean the oven regularly.
8. **Do Not Use Water on Grease Fires - Smother fire or flame or use dry chemical or foam-type extinguisher.**
9. Avoid the use of aerosol containers near the oven.
10. Never place pans, cookie sheets or roasters directly on the oven bottom. Use the rack in its lowest position. Do not use aluminium foil.
11. Allow at least 1" of space all around pots, pans or cookie sheets in the oven to permit convection air flow.

To fully enjoy your new oven, it is important that you read this manual thoroughly.

Installation

Unpacking

1. With unit sitting on the floor, cut banding, and remove wooden crating. Cut plastic wrap and remove foam packing.
2. Have someone on the left and the right side of the unit lifting it up from the bottom, remove all packaging materials around and under the unit.
3. Set unit on a table or some other supporting platform, so that the face of the unit overhangs but is not supporting any weight. Be sure to do this or the porcelain front may chip!

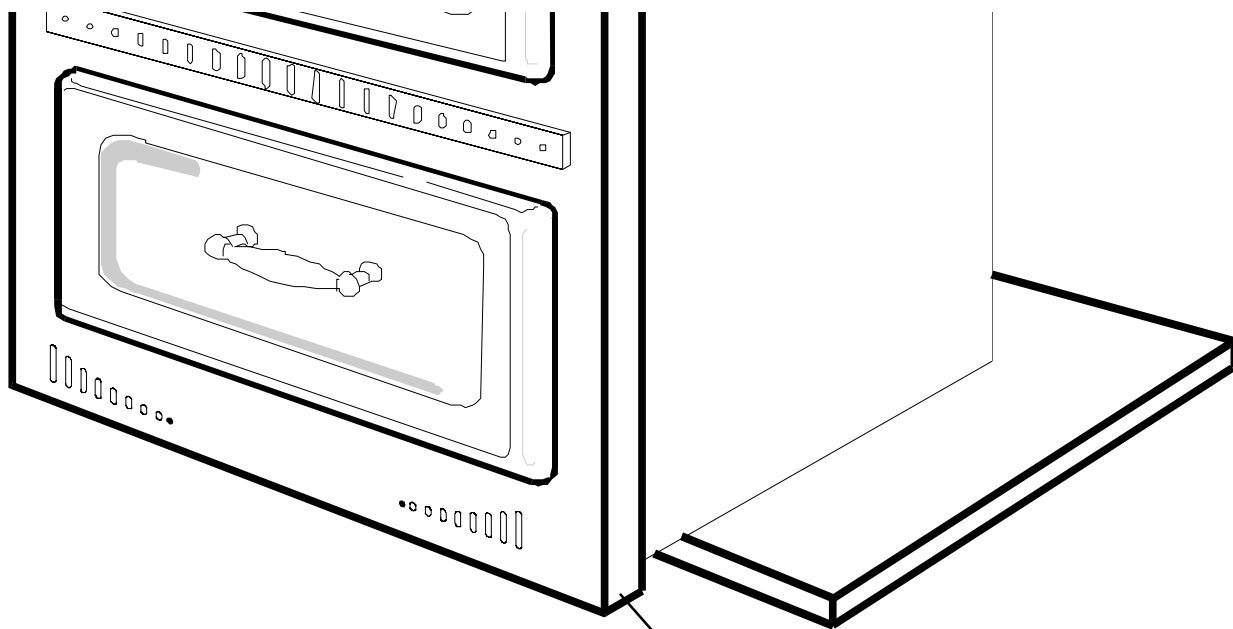

Caution : Do not set this edge on the table or the floor, as porcelain coating will chip. Always place over an edge

Prepare for Installation

This illustration shows the size of enclosure required for the appliance and the dimensions of the appliance. Dimensions are shown in inch measurement and metric centimeter measurement. For best cooking results your oven must be level. This can be checked at the final installation stage with a carpenter's level across the top of the appliance front. If levelling is required, shim the oven between the bottom of the cabinet opening and the oven bottom. Please note that the power supply box *must* be mounted in the cupboard below, modifications to the cupboard may be required.

CAUTION- Children climbing on oven to reach items could be seriously injured therefore, do not store items of interest to children in cabinet above the oven.

Please note: The wall oven face will meet your cabinet facing resulting in some heat transfer to the cabinet facing. If your cabinets have a plastic coating or veneer check with the manufacturer to ensure it was applied with a (300°F) heat resistant adhesive. If the plastic coating and the adhesive are not heat resistant, it is possible that the coating will deform or become detached, particularly along the edges that meet the wall oven.

You must have a qualified electrician connect the new oven to ensure that all electrical codes and rules are observed.

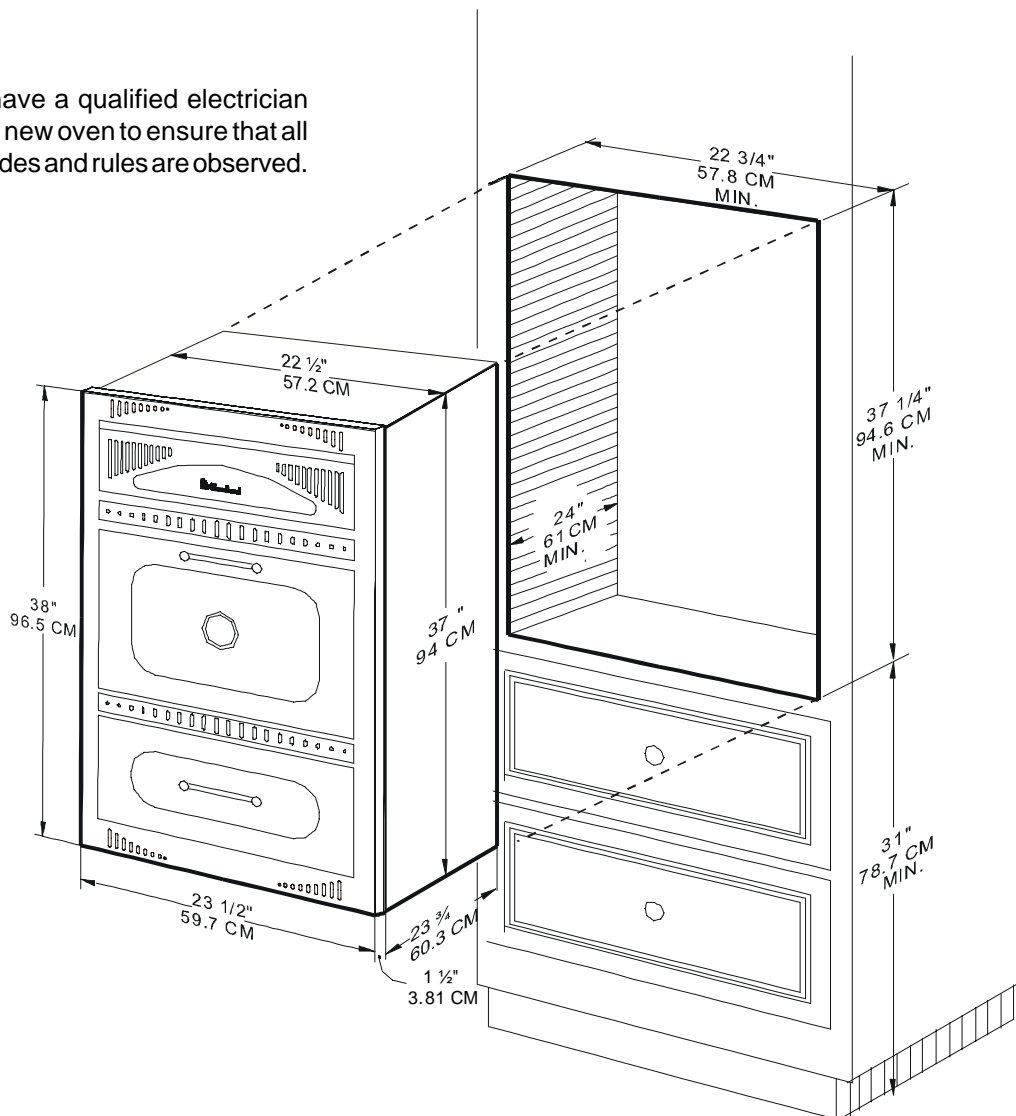

Beginning installation

1. Once the location of the unit has been determined construct an enclosure with dimensions as shown on page 4. Be sure to take your time and measure accurately.
2. At this point you will have to create the opening for the power supply box. The power supply box (included with the unit) must be mounted in the cupboard under the appliance opening. The power supply box comes with 36" cable and can be mounted anywhere within the length of the cable. At the rear of the opening and 16 1/4" from the left side, cut a slot 5 1/2" x 2 1/2" (see illustration below). Ensure that you can easily slide the supply box through it. (The power supply box is permanently attached to the appliance and is mounted *after* the appliance is installed.)
3. Screw the anchor clips to the top of the cabinet opening as shown on page 6. These clips will later secure the unit to the cabinet and must be installed. Find the centre of the opening and mount the clips 7 3/16" on each side of the centre point, and extending from the opening approximately 5/8".

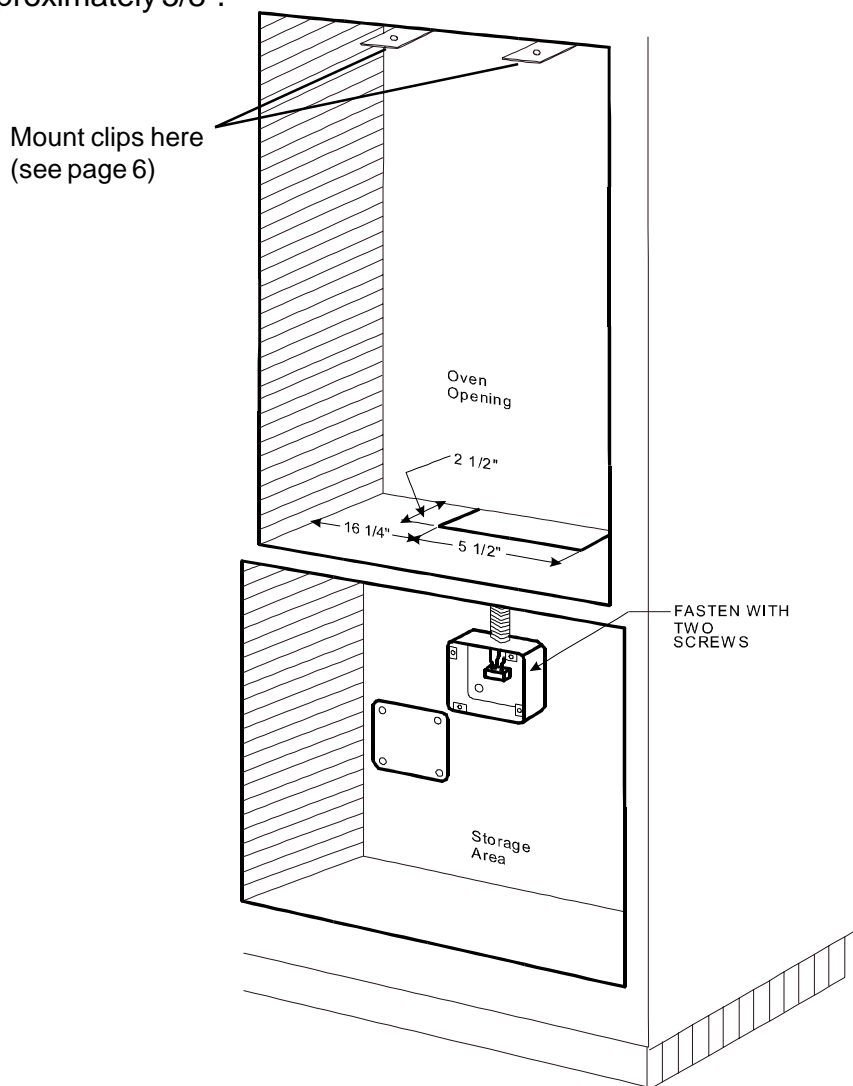

Final installation

Note: It is recommended to have two people for lifting the oven.

1. Lift the unit up to the opening and guide the supply box through the slot into the lower cupboard at the back of the opening. The power supply box and cable must be *fully* inserted into the lower cupboard or the appliance will not install completely into the enclosure.
2. Slide the unit into place and check that the unit is level by placing a spirit level across the top of appliance front. If levelling is required, shim the unit between the base and the bottom opening.
3. After unit has been levelled, secure the unit to the cupboard with two screws along the top, into the two anchor clips installed previously. (see below and page 5 illustration)
4. Remove cover of the power supply box and fasten the supply box to the back of the cupboard

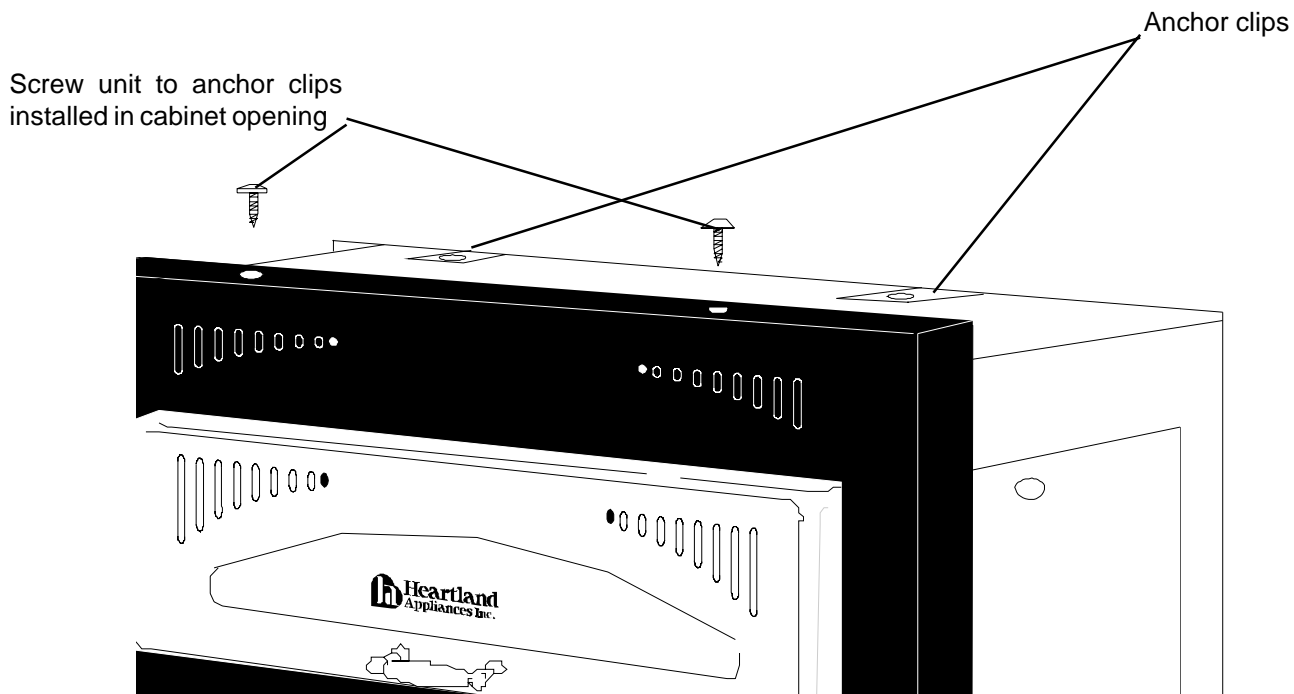

below with four wood screws (See page 5).

5. The unit can now be wired into the power source by a qualified electrician.
6. Before turning the unit on please read “Before you Start” under the Operation section on page 10.

Note:

The oven face should not go inside the opening. Following these directions the face-plate will over lap the cabinet by 1/4" top and bottom and on the sides. The flange will extend 1 1/2" off the face of the cabinet when mounted.

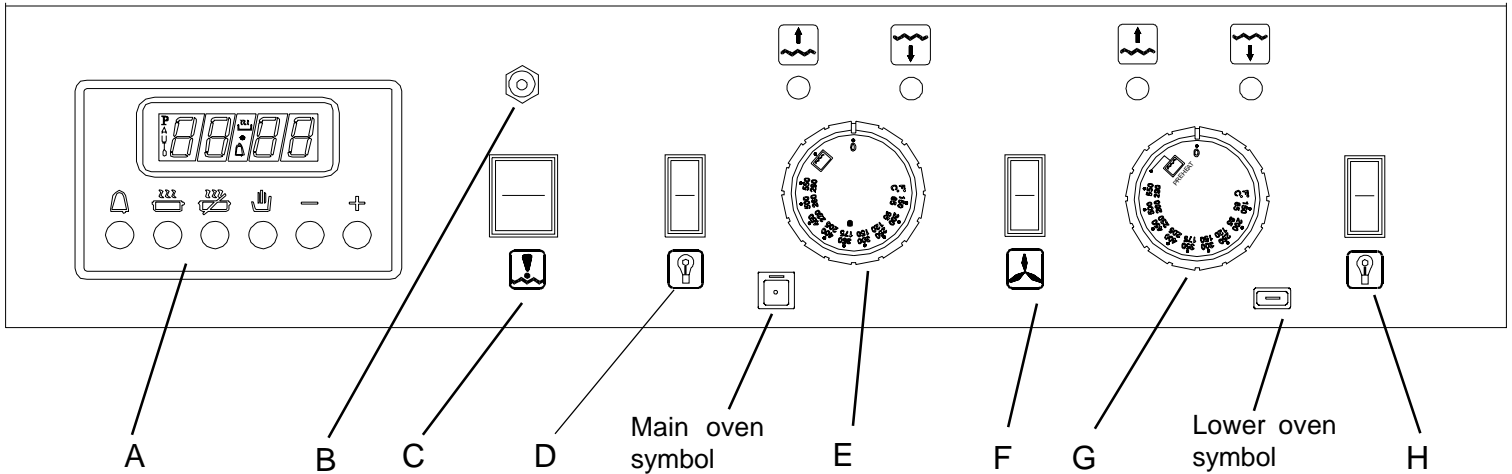

Features



Dual Oven Control Panel Features



#9730 Self Clean

- A) Digital Timer - With minute minder and automatic stop and start cooking and self clean functions.
- B) Self clean oven reset button (self clean only)
- C)  Rocker Switch, controls self clean function (see page 14)
- D)  Oven light on/off switch. Up position is "Off"
- E) Main Oven Temperature Control in Fahrenheit and Celsius with -



bake indicator



broil indicator

- F)  On/off switch - Controls convection fan for regular baking/broiling and convection baking/broiling. Up position is "Off"



Lower Oven Controls:

- G) Lower Oven Temperature Control -



bake indicator



broil indicator

- H)  Oven light on/off switch. Up position is "Off"

- I) Control Panel door Cover :

Dual Oven Features

door slides up into the unit to reveal control panel with timer, light switches, oven indicators and controls. Also houses self clean control.

J) Main Oven:

- baking, broiling
- timed baking, broiling
- convection baking, broiling
- timed convection baking, boiling
- 4 position racking
- 2.7 cubic feet of energy efficient baking area (.07 cubic meters)
- self clean feature

K) Lower Oven :

- for regular baking and broiling
- 2 position racking.
- 1.5 cubic feet of energy efficient baking area (.04 cubic meters)

L) A grease filter is included that may be fitted onto the fan shield to limit grease build-up when roasting or broiling meats in an uncovered vessel in convection mode.

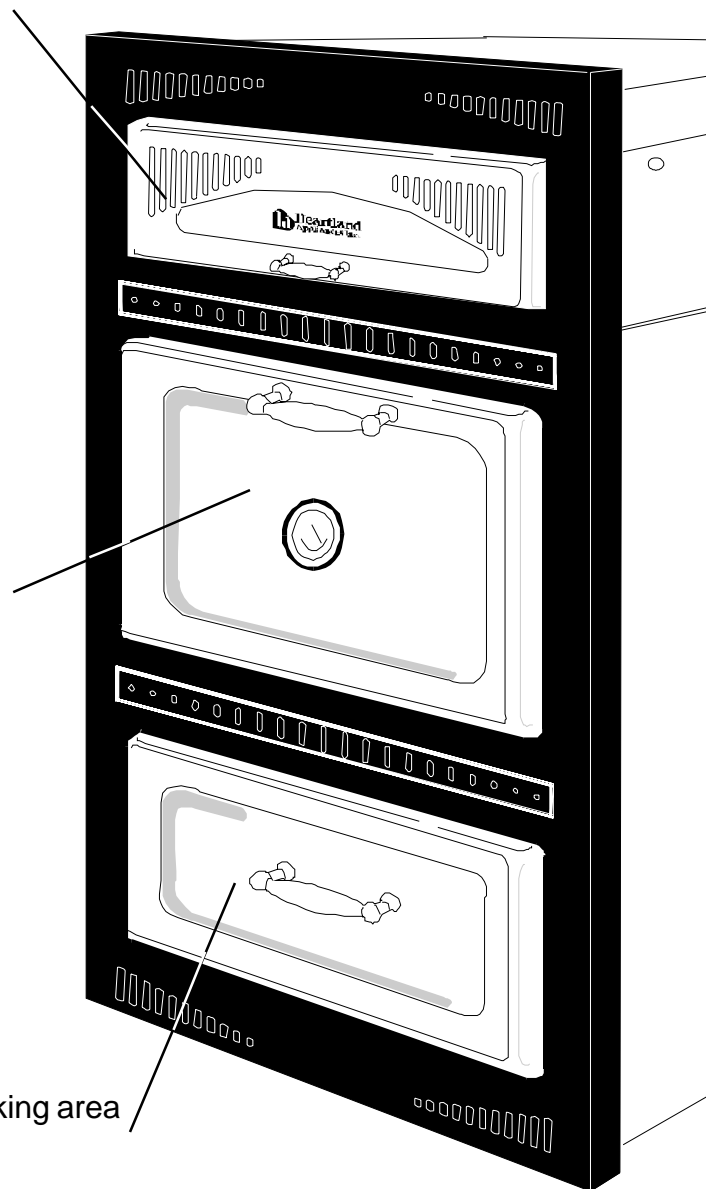

Important Safety Instructions

Oven Safety

DO NOT TOUCH HEATING ELEMENTS OR INTERIOR SURFACES OF OVEN—Heating elements may be hot even though they are dark in color. Interior surfaces of an oven become hot enough to cause burns.

During and after use, do not touch, or let clothing or other flammable materials contact heating elements or interior surfaces of oven until they have had sufficient time to cool.

Other surfaces of the appliance may become hot enough to cause burns. For example, oven vent opening surfaces near these openings and oven doors. Do not set cooking utensils directly on oven floor!

Note: In the lower oven the bake element is contained under the oven floor. This facilitates easier cleaning and more usable space in the oven.

1. Use care when opening door - let hot air or steam escape before removing or replacing food.
2. Do not heat unopened food containers - build-up of pressure may cause container to burst and result in injury.
3. Keep oven vent ducts clear of obstruction. **See illustration below**
4. Placement of oven racks—always place oven racks in desired location while oven is cool. If rack must be moved while oven is hot, do not let pot holder contact hot heating element in oven.

Self Clean Safety Instructions

Read the instructions below and the appropriate timer instructions before attempting to operate. Do not leave food or cooking utensils, etc, in the oven during self-cleaning mode of operation.

Do not touch heating elements or interior surfaces of oven—heating elements may be hot even though they are dark in colour. Interior surfaces of an oven become hot enough to cause burns.

During and after use, do not touch, or let clothing or other flammable materials to contact heating elements or interior surfaces of oven until they have had sufficient time to cool.

Other surfaces of the appliance may become hot enough to cause burns—among these surfaces are, for example, oven vent openings, oven doors and surfaces near these openings.

1. Remove utensils and cookware from the oven. Oven racks and rack supports should be removed from the oven. Racks and supports left in the oven during self clean will become discoloured, but it will not affect the protective coating.
2. DO NOT clean the gasket. The door gasket is essential for a good seal. Care should be taken not to rub, damage or move the gasket.
3. Never use a commercial oven cleaner in a self cleaning oven. This will damage the finish.
4. Make sure the convection fan and oven light is off. The convection fan and light switch must be turned off at the control panel.

Vents must be kept clear of obstructions

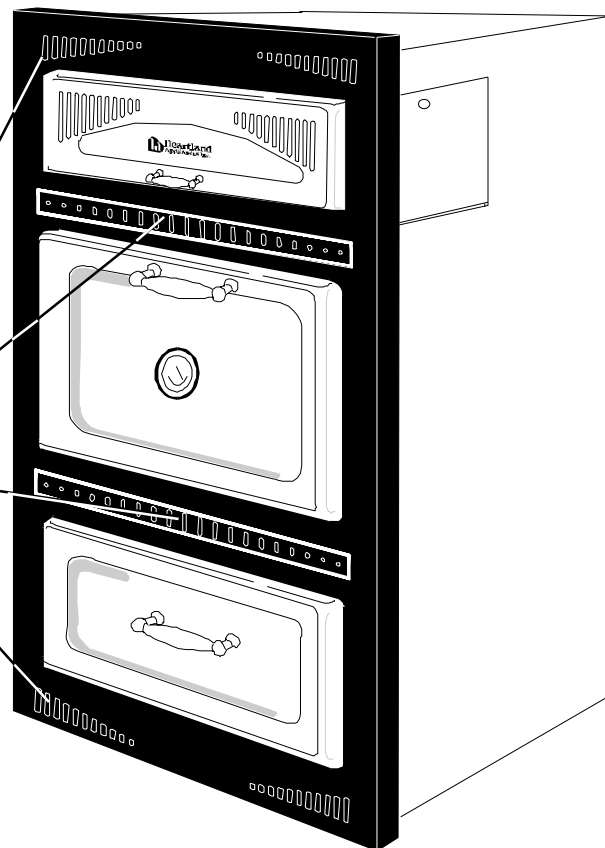

Operation

Before You Start

1. Remove the oven racks and oven rack supports and clean with soap and water. (see oven rack and support removal pg.29).
2. Unwrap broiler pan and clean with soap and water.
3. Clean both ovens with soap and water, making sure that all adhesives have been removed.
4. Set the clock to the correct time of day. See page 12 for instructions on how to set the clock. **Please note that the clock must be set for the main oven to work.**
5. Install grease filter on fan baffle, by hooking the filter onto the grill of the fan baffle. This filter is not required for regular baking or broiling, but should be on when open vessel convection broiling or convection broiling.

Getting to Know Your Oven

The main oven features multi level regular baking/broiling in timed or untimed modes. For energy efficient batch baking, choose convection baking, which allows you to bake on multi levels simultaneously. For traditional baking the convection feature should be OFF.

The lower oven also features multi level baking/broiling, the bake element is hidden beneath the floor of the oven, so cleanups are fast and easy. Please note that the lower oven is disabled and will not function during the self clean mode of operation

The OVENLIGHTS are activated by switches located on the control panel. Your oven has a temperature range of 150° F TO 550° F 66°C to 290°C). The oven **Cycling Light** glows until the oven reaches the selected temperature, then cycles off and on during cooking. See pages 19 and 22 for recommended baking and roasting times and temperatures.

Note: *Do not engage the self clean oven door latch when not in self clean mode, as it is possible the oven door safety interlock will activate at high oven temperatures.*

Bake - Broil Controls

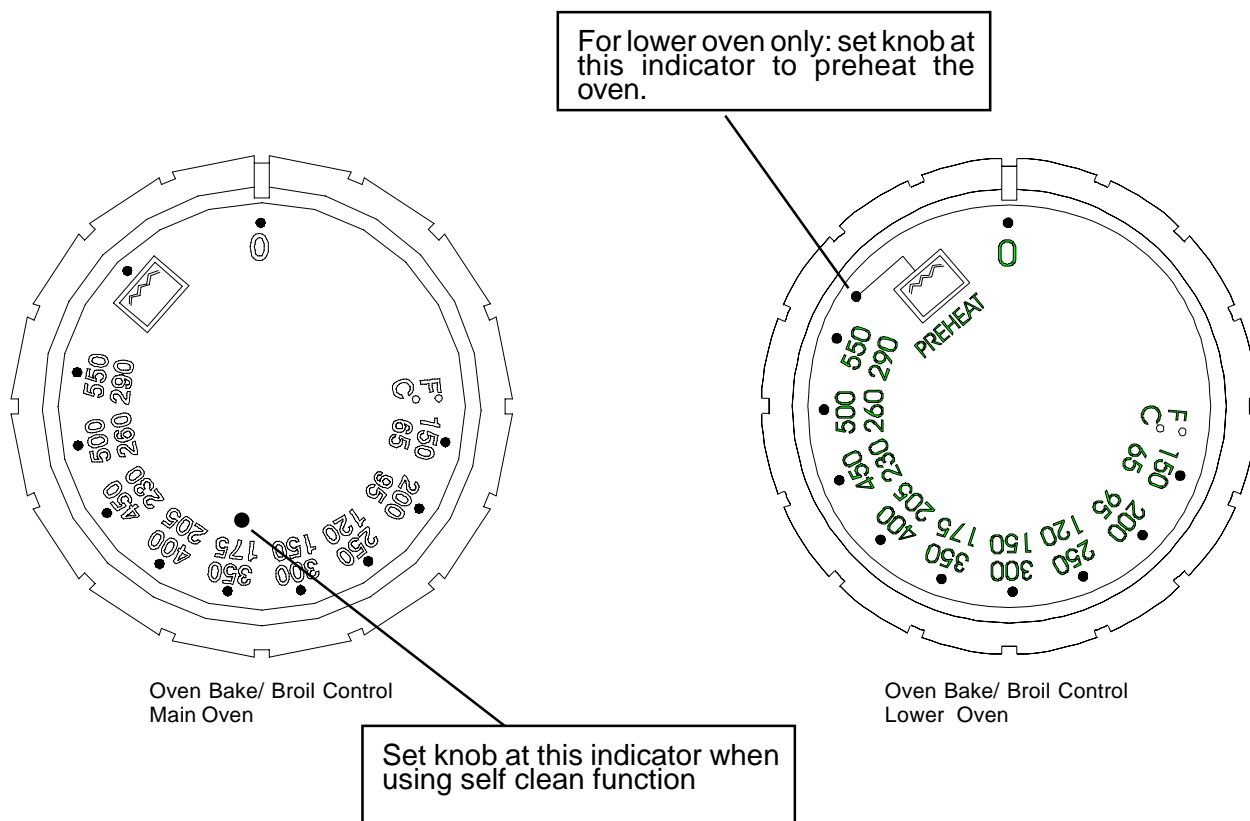

Baking

Main Oven: To bake, push down and turn the oven control counter clockwise to any desired temperature. When baking is selected, the indicator under the bake symbol lights up, and the bake element will activate. After the oven has reached the temperature you have selected, the element will cycle on and off to maintain temperatures.

Lower Oven: To bake push down and turn the oven control counter clockwise to any desired temperature. When baking is selected the indicator under this symbol lights up. **Select preheat for approximately 6 minutes**, to get the oven up to temperature quickly, then select desired temperature. **Do not place food in the oven when preheating with the broil.** After the oven has reached the temperature you have selected, the element will cycle on and off to maintain the temperature.

The temperature is infinitely variable between temperatures 150°F and 550°F (65°C and 290°C.)

Broiling



To activate broil (top element), turn oven control to broil (end stop position). When broiling is selected, the indicator under this symbol lights up. To de-select broiling, turn the oven control knob to a temperature setting, which resets the control to baking mode.

Operation

Clock / Timer Setting

For both 9720 and 9730 models

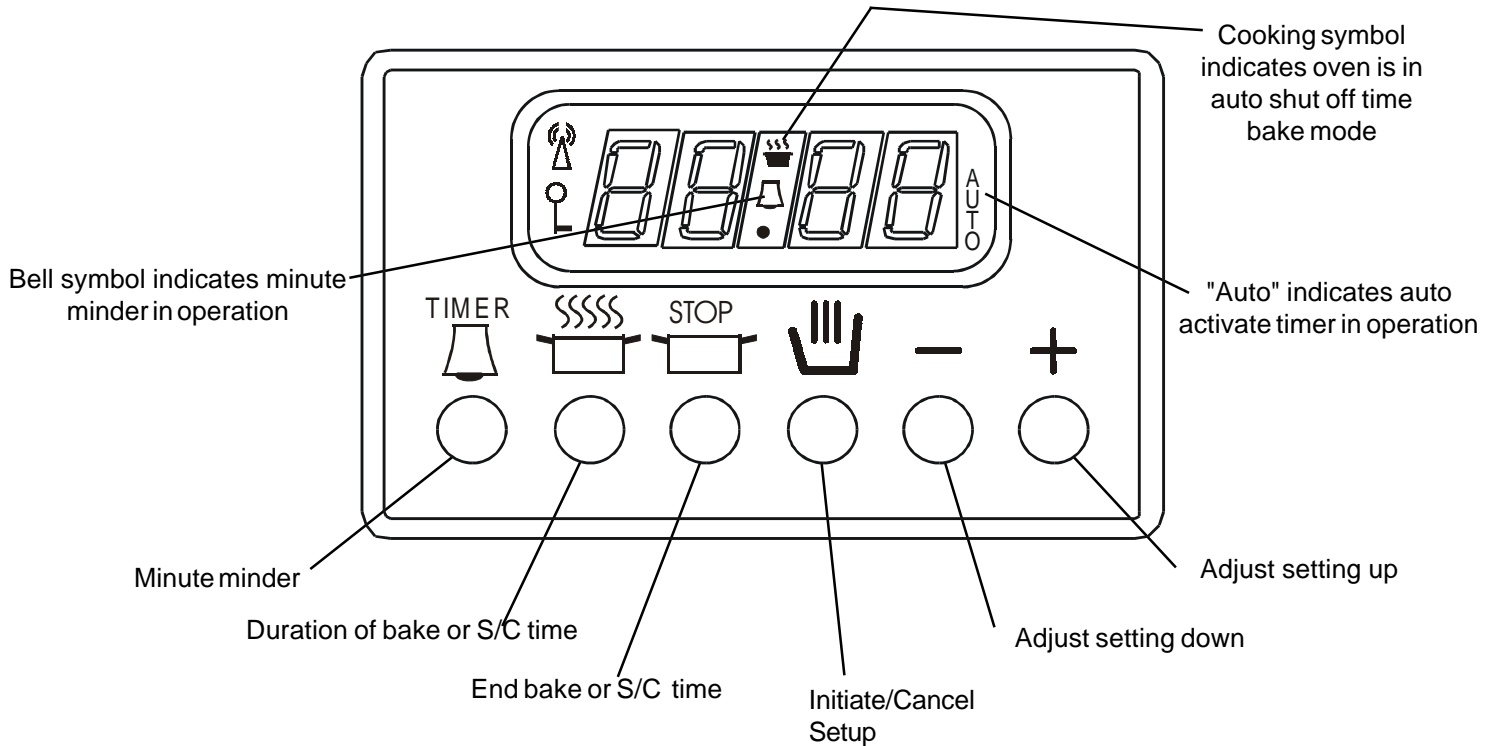

Time of Day Setting **NOTE: Clock must be set or your main oven will not function!**

1. To set the time of day:

a) the clock read-out will be flashing "**0:00**" and "**AUTO**" alternately. (at first time set up or after a power failure)

b) press "🔊" and "🔔" buttons simultaneously to activate the clock time adjustment. The display will stop flashing except for the "**AUTO**" symbol. You will have 3 seconds to start the next step.

c) tap "⏩" to advance time, or "⏪" to decrease time, the display will begin at "**12.00**". Press and hold to advance time quickly. Set to the correct time of day (the clock is based on a 12 hr cycle).

d) once the time of day has been entered, the "**AUTO**" symbol will stop flashing, the clock is set and the appliance is ready to use.

e) time of day may be adjusted at any point by pressing the "🔊" and "🔔" buttons and then pressing "⏩" or "⏪" setting buttons.

Minute Minder

1. **To set timer:** (the minute minder can be at any time even when in timer modes)

a) press "🔔" the **minute minder button**.



b) Set the timer in minutes using the "⏩" and "⏪" **setting buttons**.

c) The timer activates **5 seconds** after the setting buttons are released, and returns to time of day mode.

d) when the set time has been reached the timer will sound, 2 distinct beeps.















e) to see time remaining on timer press "🔔" at any time.

2. To cancel minute minder operation:



- a) press "".
- b) press "" setting button and **set to zero**.
- c) then press "" cancel button and the display will return to time of day mode.

Time Bake (for main oven only)

1. To set time bake:

- a) if convection is desired activate the convection fan rocker switch marked "" on the control panel below the timer.
- b) press the "" bake duration button.
- c) use the "" and "" to set the **length of time** you want the oven to be in operation. (The "" and "" setting adjust buttons work in **1 minute** intervals). The oven will now turn off after the time entered has elapsed.
- d) to have the oven turn on at a specific time, next, press the "" end bake time button.
- e) use the "" and "" to set the **actual time of the day** you want the oven to shut off. After 5 seconds the display will return to time of day mode. The **"AUTO"** indicator will light up, showing the timer is in operation, and the "" symbol will shut off, indicating the oven is off until the timer activates the oven.
- f) set Temperature Dial to desired cooking temperature. The timer calculates the start time by subtracting the cook time from the time of day you want the oven to shut off.
- g) when the **bake cycle begins**, the "" symbol will light up showing that the oven is in operation.
- h) when the **time bake cycle** is complete, the **"AUTO"** indicator will flash, the "" will shut off indicating the oven is off and the timer will sound (4 distinct beeps).
- i) the timer will sound until the "" **cancel button** is depressed. The **"AUTO"** indicator will flash and the oven will not work until the and the "" button is depressed a second time. Remember the turn off your oven control.

2. To cancel time bake:

- a) anytime during the time bake cycle depress the "" bake duration button and set the time to zero, and depress the "" **cancel button** to return to time of day mode.
- b) the minute minder can still be used during the time bake cycle.

How to Self Clean

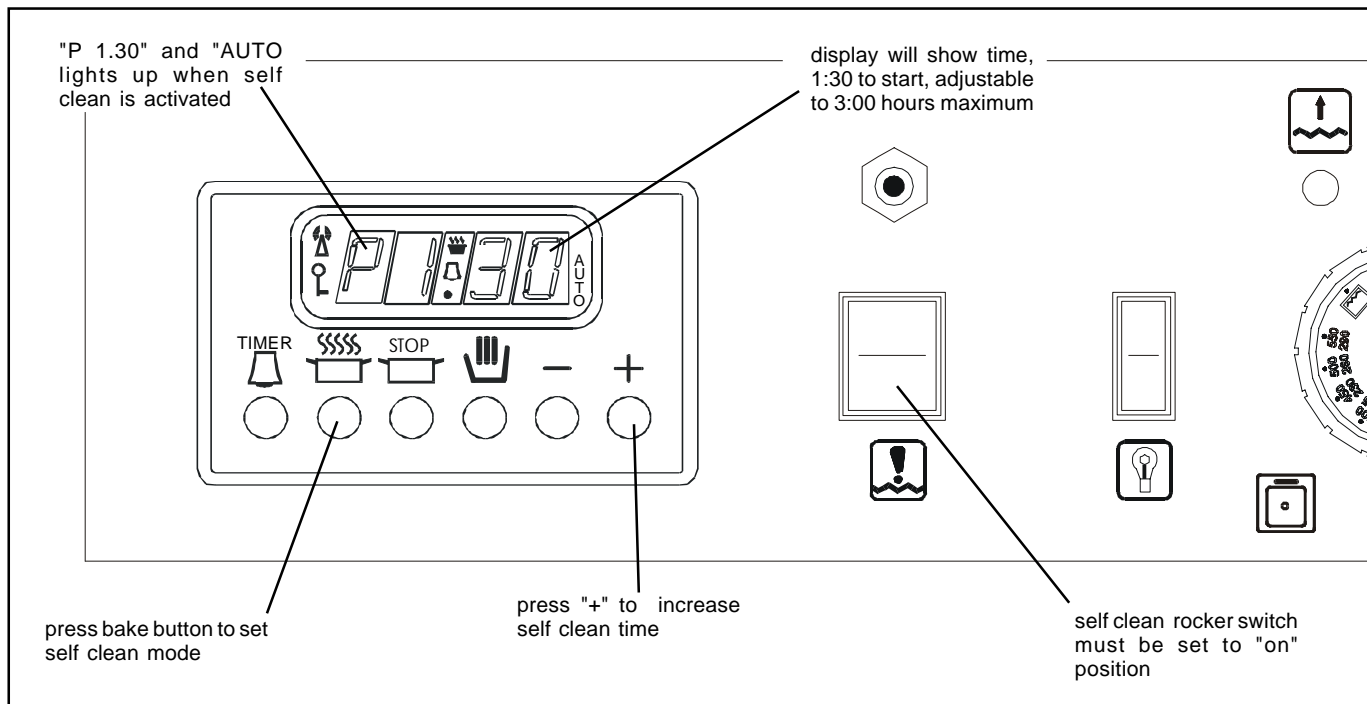

Figure A - self clean control panel layout

How to Self Clean

The recommended self clean time is 3 hours. The cycle can be set however, anywhere from 1 hour 30 minutes for light soiling, to 3 hours maximum for heavy soiling. Please note that the lower oven is disabled and will not function during the self clean mode of operation.

Be sure the self clean safety instructions have been followed.

1. Lock the oven door by pushing the self clean door latch fully to the right. (see fig. B)
2. The clock will display "P1.30" which indicates one hour thirty minutes of self clean time. As well "🔥" and "AUTO" symbol will light up, indicating the self clean cycle is active.
3. Press bake "🔥" button on the clock

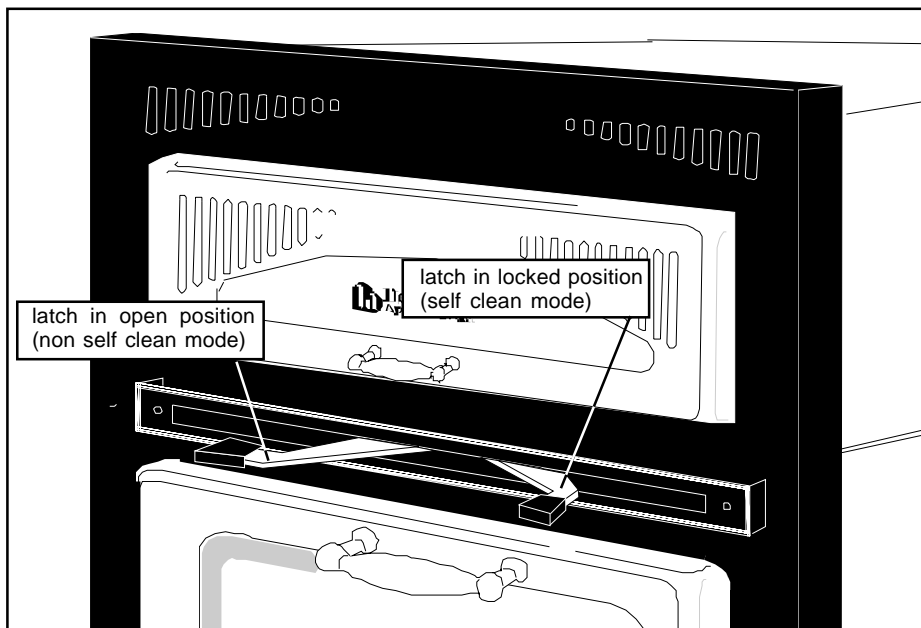

Figure B - self clean latch positions

4. Tap the "+/-" button for additional self clean time in one minute increments. Press and hold to advance quickly to 3:00 hour maximum. 3 hours is recommended for maximum cleaning.

5. Turn the oven thermostat control knob clockwise until it can no longer be turned (see fig c). Bake indicator will come on.
6. Your oven is now in the self clean mode and will operate in self clean mode for the time you have set.
7. At the end of the cycle the oven will shut off and the clock will flash "P0.00" and the symbol "AUTO" alternately.
8. Turn the thermostat control knob to "0". The clock will flash until the the oven is unlocked.
9. The safety interlock is active until the oven has cooled to a safe temperature (approximately 1 hour) You will not be able to unlock the oven door during this cool down period. Please do not attempt to open door while locked, or damage to locking mechanism may occur.

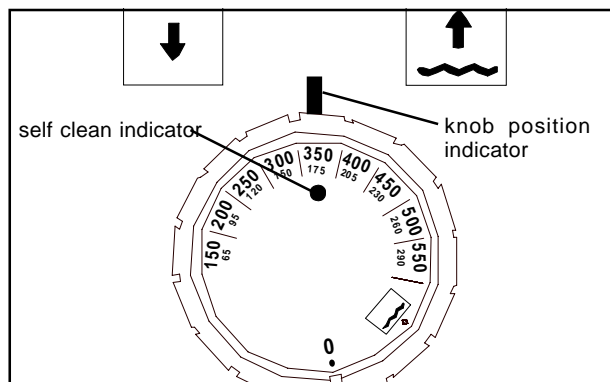

Figure c Oven thermostat knob position for self clean.

Caution: Even after the oven door lock has released the oven may still be too hot to touch. Use caution to avoid burns.

10. When the oven has sufficiently cooled, wipe away the remaining grey ash with a damp cloth.

DANGER: If a large amount of smoke comes out of the oven vent it is probably because you have left something in the oven or the warming drawer. Turn off the oven thermostat control. Allow the oven to cool and use caution when removing any utensils or debris, to avoid burns.

Note: Self clean mode may be cancelled at any time... by turning the oven thermostat control back to "0". Unlatch the self clean door latch.



Remember, the safety interlock is active until the oven has cooled to a safe temperature - do not attempt to force open.

Time Delay Self Clean

To set TIME DELAY self clean

1. Lock the oven door by pushing the self clean door latch fully to the right. (see fig. B)
2. The clock will display "P1.30" which indicates one hour thirty minutes of self clean time. As well "🔥" and "AUTO" symbol will light up, indicating the self clean cycle is active.
3. Press bake "🔥" button on the clock
4. Tap the "⊕" button for additional self clean time in one minute increments. Press and hold to advance quickly to 3:00 hour maximum. 3 hours is recommended for maximum cleaning.

5. Next, press the "  " end time button, the display will change to show the time of day.

6. Use the "  " or "  " to set the **actual time of the day** you want the oven to shut off. After 5 seconds the display will change to show self clean time remaining, the "AUTO" indicator will remain lit, and the "  " symbol will shut off showing the oven is not in operation and delay timer is active.

7. Turn the oven thermostat control knob, to the self clean position. (see fig C, previous page)

8. Your oven is now in the delay self clean mode and will operate for the time you have set.

9. When the **self clean cycle begins**, the "  " symbol will light up showing that the oven is in operation and will be in the self clean cycle for the length of time on the display.

10. At the end of the cycle the oven will shut off and the clock will flash "P0.00" and the symbol "AUTO" alternately.

11. Turn the thermostat control knob to "0". The clock will flash until the the oven is unlocked.

12. The safety interlock is active until the oven has cooled (approximately 1 hour) You will not be able to unlock the oven door during this cool down period. Please do not attempt to open door while locked or damage to the locking mechanism may occur.

Caution: Even after the oven door lock has released the oven may still be too hot to touch. Use caution to avoid burns.

13. When the oven has sufficiently cooled wipe away the remaining grey ash with a damp cloth.

DANGER: if a large amount of smoke comes out of the oven vent it is probably because you have left something in the oven or the storage drawer. Turn off the oven thermostat control. Allow the oven to cool and use caution when removing any utensils or debris, to avoid burns.

To cancel time delay self clean:

Turn the oven thermostat control knob, to the "0" position.

How to Select Cooking Methods

for "Main and Lower" Ovens



Standard Cooking

To bake, turn the oven control to any desired temperature between 150°F to 500°F (66°C - 290°C). When baking is selected, the indicator below this symbol lights up, and the bake element will activate. Preheat the oven if the recipe calls for it, approximately 5-10 minutes. After the oven has reached the temperature you have selected, the bake element will cycle on and off to maintain temperatures. Do not rotate control past 500°F (290°C) for bake as this is the broil position and only top element will come on.

Standard Cooking / Baking

This is the traditional "radiant heat" style of cooking. You may choose this method of cooking for your tried and true recipes. As with all radiant style ovens, it will be necessary to preheat the oven, especially for baked goods. Usually your recipe will state whether or not preheating is required. When roasting meats from frozen to finish, usually preheating is not required. However allow 1/3 to 1/2 more cooking time depending on the size of the cut. To assure desired degree of doneness, use a meat thermometer for meats and poultry.

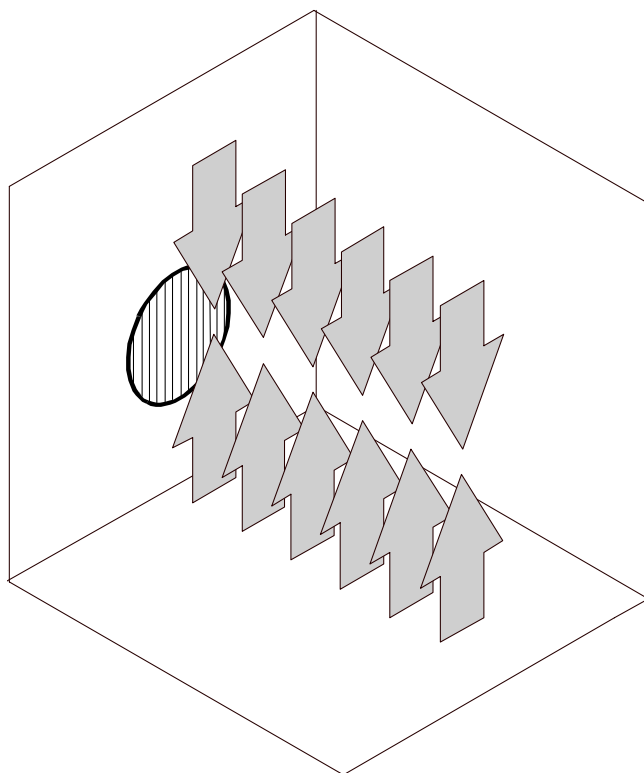

Radiant Heat Pattern

Diagram shows how heat is radiated from the elements, during the cooking process



Standard Broiling

To activate broil (top element), turn oven control to broil symbol "  " on the knob. When broiling is selected, the indicator under this symbol lights up. At this setting the broil element comes on and stays on. To de-select broiling, turn the oven control knob to a temperature setting, which resets the control to baking mode. When broiling, the oven door should be completely closed, and the grease filter installed.

Standard Broiling

This method of cooking is used to transfer high heat over a short period of time to food placed in close proximity to the broiler element. Usually used to brown the surface of food, such as meringues, steaks and roasts.

Place meat on the broiler pan (add water to the bottom of the pan to reduce smoking). Place the broiler pan on the third or fourth rack in the main oven, and first or second rack in the lower oven, depending on the food and your personal tastes.





Convection - These convection selections are for "Main Oven" only.

When the rocker switch in the control panel is set to this symbol, the convection fan will be activated. The convection fan can be operated in three modes.

- 1) convection baking.
- 2) convection broiling.
- 3) convection drying.

Convection Baking - select a temperature on the oven control and then select "  " above the rocker switch. Oven is now in "Convection Bake Mode".

Convection Broiling - select "broil" on the oven control and select "  " above the rocker switch. The oven door should remain completely closed while in Convection Broil Mode.

Convection Drying - leave temperature control at "0" and select "  " above the rocker switch. The convection fan has been activated and oven is now ready to dry spices or fruits.

For time bake, when the rocker switch is set to this symbol "  " and the timer and temperature controls are set, the fan will then automatically activate when the selected time has been reached. For more detail on "Time Bake" see page 13.

Convection Cooking

Convection Cooking - Convection means conveying.

So in convection cooking, the heat is conveyed by moving air by means of a fan. The circulating hot air penetrates food faster than motionless air in a standard oven. Thus you can cook at a lower temperature, therefore reducing amounts of energy used and sometimes cook in a shorter time.

Convection Roasting

This method of cooking uses both hot air and radiant heat, and is similar to rotisserie cooking, where high heat is applied quickly and evenly around the meat, but instead of rotating, hot air circulates around the meat. Place the cut of meat directly on the third oven rack position with the broiler pan on the rack below to catch any drippings. Poultry should be placed breast down for the first half of the cycle then turned over, this keeps the breast moist. Other meats should be placed on the rack, fat side up, and usually do not require turning.

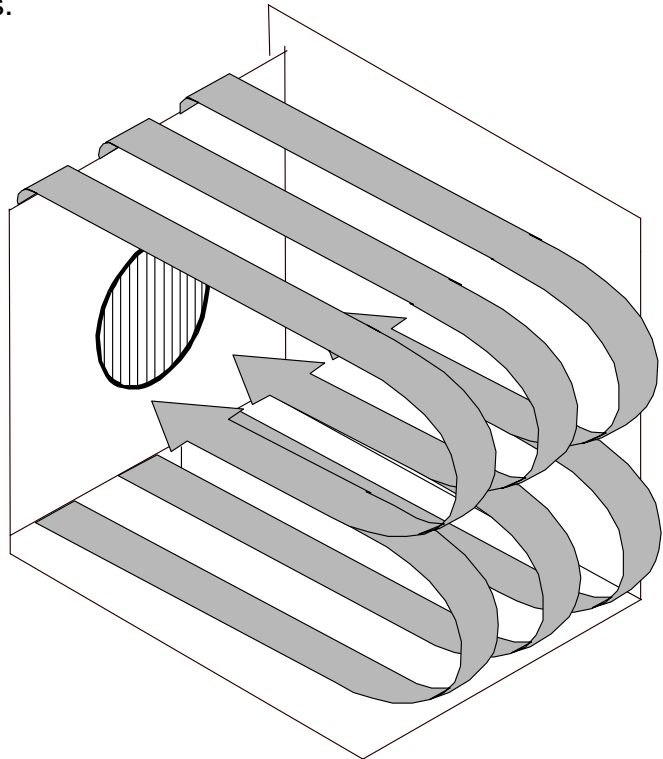

Convection Air Pattern

Diagram shows how heat is circulated from the convection fan, distributing heat evenly around the food, during the cooking process

Roasting Times and Temperature Guide

All times are approximate since variables such as size, shape and temperature of meat will affect the cooking time. Use a meat thermometer inserted into thickest part of the meat, avoiding bone and muscle to accurately determine doneness. Convection cooking will cook faster. Times can often be reduced up to 25 -30 % , therefore meat should be checked shortly before the suggested minimum cooking time. Insert the grease filter before convection roasting. Allow meat to stand about 15 minutes before carving.

Food	Degree of Doneness	Internal Temperature		Approximate Cooking Time for Regular Oven
		° F	° C	
BEEF				
Sirloin or rib roasts	Rare	140	60	20 -25 min. / lb (45 - 50 min. / kg)
	Medium	160	70	25 - 30 min. / lb (55 - 60 min / kg)
	Well-done	170	75	30 -35 min. / lb (65 - 70 min. / kg)
Rump, round (roast at 275°F /140°C. OR in convection at 250°F /120°C.)	Rare	140	60	40 - 45 min. / lb (80 - 85 min. / kg)
	Medium	160	70	45 - 50 min. / lb (90 - 95 min. / kg)
VEAL				
Leg, loin, rib roasts	Medium	160	70	30 -35 min. / lb (65 - 70 min. / kg)
	Well-done	170	75	35 - 40 min. / lb (75 - 80 min. / kg)
PORK				
Leg or loin roast	Done when there is a hint of pink when sliced	160	70	20 -25 min. / lb (45 - 50 min. / kg)
Crown roast	Done when there is a hint of pink when sliced	160	70	15 - 20 min./ lb (25 30 min. /kg)
Shoulder roast	Done when there is a hint of pink when sliced	160	70	25 - 30 min. / lb (35 - 40 min. kg)
HAM				
Smoked, pre-cooked	Heated until hot	140	60	10 -15 min / lb (22 - 25 min. / kg)
LAMB				
Leg	Rare	140	60	20 -25 min. / lb (45 - 50 min. / kg)
Leg, shoulder roasts	Medium	160	70	25 -30 min. / lb (55 - 60 min. / kg)
	Well - done	170	75	30 - 35 min. / lb (65 - 70 min. / kg)
Rack (roast at 400°F / 200°C. or in convection at 375°F / 200°C.)	Rare to medium	140 to160	60 to 70	10 -18 min. / lb or 0.5 kg

Broiling Tips

1. Prepare meat, allowing frozen meat to thaw before broiling.
2. Slit the fat around the edge of the meat about every inch, to prevent curling. Arrange meat on the broiler pan.
3. A small amount of water placed in the broiler pan will reduce the smoke and splattering from hot drippings.
4. Always use the broiler pan and rack supplied. They are designed to allow fats to drip into the pan, reducing smoking while the food is cooking. If desired the broiler pan may be lined with foil and the broiler rack may be covered with foil. However be sure to mold the foil to the broiler rack and cut slits in the foil to conform with the slits in the rack to allow juices and fat to drain into the pan.
5. Place the oven rack in the desired position near the top of the oven.
6. Hook the grease filter (provided) on to the fan shield to prevent grease build-up when roasting or broiling.
7. Turn the oven control to broil.
8. Allow the oven to preheat for 8 minutes.
9. Place the broiler pan and food on the oven rack.
10. Completely close the oven door.

***Caution: Accessible parts may become hot when the broiler is in use.
Children should be kept away.***

11. The closer the meat is placed to the broil element, the faster the surface browns. For rare meat, preheat the broiler unit and place the meat as close to the unit as possible.
12. The further away the meat is placed, the slower the surface browns and the more well done the meat will be.

Broiling Guide

All times are approximate since variables such as thickness , temperature and individual preferences will affect the cooking time. Broil meat on rack of broiler pan placed on oven shelf in fourth or fifth position , about 4 - 5 in (10 -12 cm) below the top element. Turn meat with tongs, not a fork so as not to pierce meat and loose juices.

Food	Degree of Doneness	Thickness	Approximate Time
BEEF			
Steaks	Rare	3/4 -1 in (2 cm)	5 -6 min. / side
	Medium	3/4 -1 in (2 cm)	7 -8 min. / side
Ground beef patties	Well done or internal temperature of 160°F / 70°C	3/4 in (2 cm)	6 - 8 min../side
PORK			
Pork chops or kabobs	Just until no longer pink	3/4 - 1 in (2cm)	5 - 6 min. / side
LAMB			
Lamb chops or kabobs	Medium -rare	1 in (2cm)	5-7 min. /side
CHICKEN			
Chicken parts	until juices run clear		25 - 40 min. total
Boneless breasts	until no longer pink		6 -8 min. /side
FISH			
Whole or steaks	until it flakes with a fork		10 min. / in.(2cm)
Boneless fillets	until it flakes with a fork		5-10 min. total
Lobster tails, thawed			8-10 min. total

Baking Time and Temperature Guide

(in a preheated oven)

OVEN TEMPERATURES: Unless otherwise indicated preheat standard oven to 325°F /160°C. Convection oven does not need to be preheated but temperatures are generally reduced by 25°F/15°C or set at 300°F /150°C. If more browning is preferred set the convection temperature at 325°F /160°C. Keep a record of your preferred temperatures and times.

Food	Regular Oven Temperature		Cooking Time	Convection Oven Temperature		Cooking Time
	°F	°C		°F	°C	
BREADS						
Yeast loaf	400	200	35 - 40 min.	375	190	25 - 30min.
Yeast rolls	375	190	15 - 20 min.	325	160	6 -10 min.
Pizza	425	220	15 -20 min.	400	200	12 -18 min.
Muffins	375	190	20 -25 min.	325	160	12 -20 min.
Tea biscuits	450	230	12 -15 min.	425	220	8-12 min.
CAKES						
Layer	350	180	35 - 40 min.	300	150	20 -25 min.
Angel food	325	160	55 -60 min.	275	140	40 - 45 min.
Cupcakes	350	180	20 -25 min.	300	150	15 -20 min.
PIES						
Shells without filling	425	220	10 -12 min	350	190	8-10 min.
Double crust with filling	450 at first and then 375	230 at first and then 190	15 min.at first and then 30 - 40 min	400 at first and then 350	200 at first and then 180	15 min.at first and then 20 - 25 min
COOKIES						
Drop or refrigerator	400	200	12 - 15 min.	325	160	6 -12 min
Rolled	375	190	8 -10 min.	300	150	8-12 min.

Poultry Times and Temperature Guide

All times are approximate since variables such as size and temperature of poultry will affect the cooking time. Use a meat thermometer inserted in the inner thigh, avoid touching the bone to accurately determine doneness. Convection cooking will cook faster. Times can often be reduced up to 25 -30 % , therefore meat should be checked shortly before the suggested minimum cooking time. Allow to stand 15 minutes before carving.

Food	Approximate Weight	Internal Thigh Temperature when cooked		Approximate Cooking Time in Regular Oven
		°F	°C	
TURKEY				
Stuffed	6 -8 lb (3 -3.5 kg)	180	82	30 min. / lb (60 min. / kg)
Stuffed	10 -12 lb (4.5 -5.5 kg)	180	82	23 min. / lb (45 min. / kg)
Stuffed	16 -22 lb (7 -10 kg)	180	82	15 min. / lb (30 min. / kg)
Unstuffed	6 -8 lb (3 -3.5 k g)	170	77	25 min. / lb (50 min / kg)
Unstuffed	10 -12 lb (4.5 -5.5 kg)	170	77	18 min. / lb (35 min. / kg)
Unstuffed	16 -22 lb (7 10 kg)	170	77	13 min. / lb (25 min. / kg)
Half breast, boneless OR leg	1 lb (500 g)	170	77	60 - 75 min. total
CHICKEN				
Capon	5 -8 lb (2.3 - 3.6 kg)	185	85	18 -20 min. / lb (40 -45 min. / kg)
Chicken, whole, unstuffed	3 - 4 lb (1.3 - 1.8 kg)	185	85	20 - 25 min. / lb (45 - 50 min. / kg)
Chicken ,quarters		185	85	18 -20 min. / lb (40 - 45 min. / kg)

Care and Cleaning

Porcelain

Keeping it clean

The porcelain is very serviceable and simple to clean, but because it is glass, it will not withstand rough handling or abuse. Avoid extreme variance of temperatures on porcelain. Porcelain is glass and sudden changes in temperature may cause cracking. To clean porcelain surfaces, use warm, soapy water, glass cleaner or non abrasive cleaner and a soft cloth. Avoid abrasive cleaners.

If any acid based food or liquid, such as lemon juice or tomato juice, is spilled on the range, wipe it at once to prevent staining.

Note: Red appliances only - a red wax coating has been added for preparation purposes which may wear off during cleaning - this is normal and does not affect finished product.

Nickel Plated Trim

Nickel may be cleaned with any non abrasive chrome and metal polish or Windex and a soft cloth. If any acid based food or liquid, such as lemon juice or tomato juice, is spilled on the range, wipe it at once to prevent staining.

Convection Fan Filter

Filter may be removed and washed in soap and water or washed in a dish washer. To remove the filter, grasp the filter and pull upwards to unhook it from the deflector. Reverse the procedure to replace.

Oven Light Replacement

Before replacing the light bulb, disconnect the power at the main fuse or circuit breaker panel. When replacing light bulbs, wait until the oven and bulb are cool. Remove oven light lens by simply unscrewing it counter clockwise.

The bulb can then be unscrewed easily. Always handle the bulb with a dry (never wet) cloth to protect hands in case the light bulb should break.

When replacing the bulb, use only a 40 watt oven bulb available at your local hardware store or appliance dealer.

When cleaning the oven, do not touch lens with a wet cloth.

Oven Cleaning

Standard Oven (non self clean)

Your range must be kept clean and free of accumulations of grease or spillovers which may ignite. This is most important in the oven and broiling compartment.

When cleaning the oven, make sure the oven is turned "Off" and oven is cool. For simple spills, clean the oven with a strong solution of detergent, then wipe with a clean damp cloth and dry.

When food or grease has burned on the oven lining, apply a strong oven cleaning compound. Follow directions on the package, but avoid applying a strong cleaner to the front flanges or sides of end panels because it may destroy the oven door seals or plated surfaces. ***Under no circumstances should an oven cleaner be used in a hot oven.***

Oven racks, oven rack supports, and broiler pan are all removable for easy cleaning. Oven racks may be cleaned in your sink with dish cloth and detergent. If spillage has remained on the racks for an extended period, more vigorous cleaning with a steel wool soap pad may be required.

Self Clean Oven

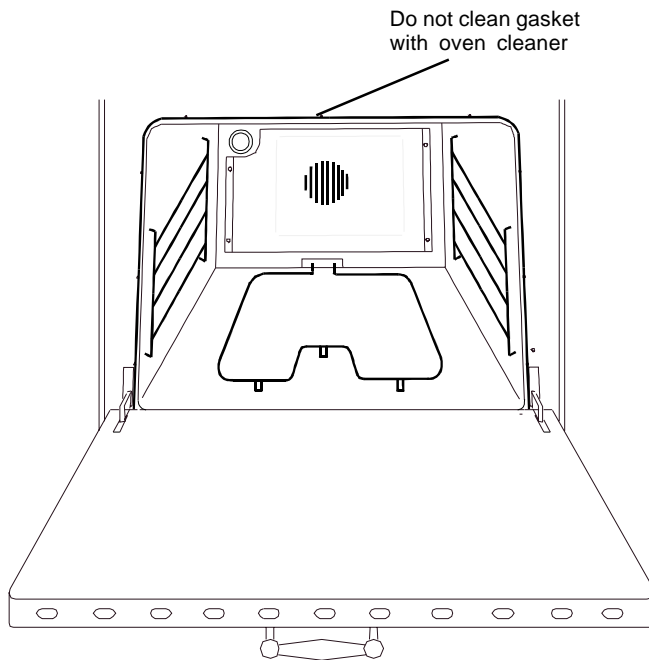

Standard Oven (non self clean)

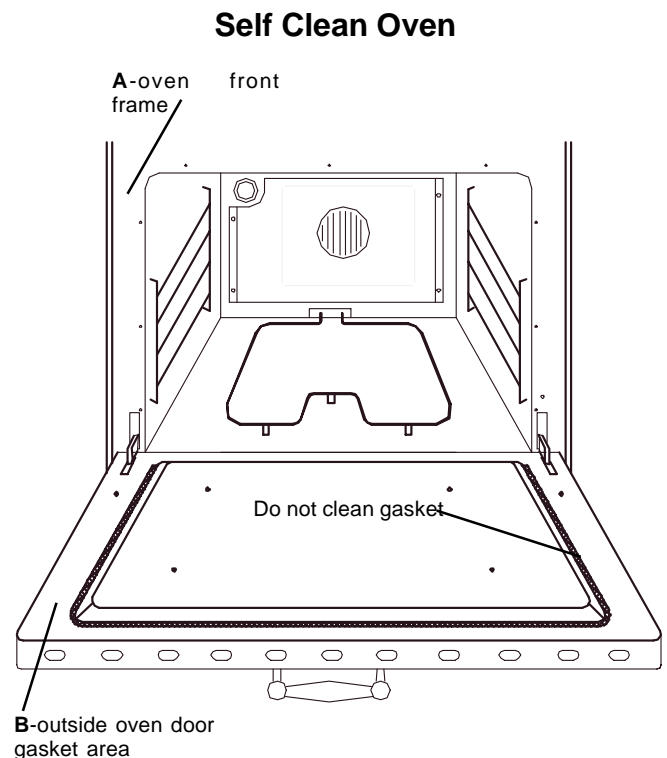

Read and Follow These Safety Instructions

Self Cleaning requires the use of the clock timer. Read the instructions below and the appropriate timer instructions before attempting to operate. After the self clean cycle is completed, the shiny luster of the oven cavity may diminish in some areas, this is not uncommon and it does not affect the operation or performance of the range.

1. Remove cookware from the oven. We recommend that the oven racks and rack supports also be removed. If they are left in the oven, racks and supports will become discoloured and rough after cleaning, but it will not affect the protective coating.
2. Wipe up heavy soil on the oven bottom.
3. Clean spills on oven front frame (A) and the oven door outside of the gasket area (B) with hot soapy water and a damp cloth. These areas are outside the self cleaning area and soil will become baked on. (see illustration page 25)

4. Under no circumstances should an oven cleaner be used in a hot oven. Using an oven cleaning compound in a self clean oven will destroy the finish and create potentially dangerous fumes.

DO NOT under any circumstance use a commercial oven cleaner, or surface coating for ovens on a self clean oven. This will damage the finish.

DO NOT clean the gasket with oven cleaner

DO NOT run the convection fan or light during self clean mode. The convection fan and oven light switch must be turned off at the control panel.

The Broiling Pan

The broiling pan grille allows for the proper drainage of cooking grease into the lower pan. Both the grille and pan should always be used when broiling.

If aluminium foil is used in the bottom of the pan, be absolutely sure it does not block the drain vents along edges of the pan. Many grease fires are caused by improper use of broiling pans and/or improper use of aluminium foil.

Always remove the broiler pan from the compartment as soon as you finish broiling. It makes the pan much easier to wash and there is no chance that the pan and drippings will be forgotten. Grease left in the pan can catch fire if the oven is used without removing the grease. Let the pan cool first, then wash the pan and grille in hot soapy water.

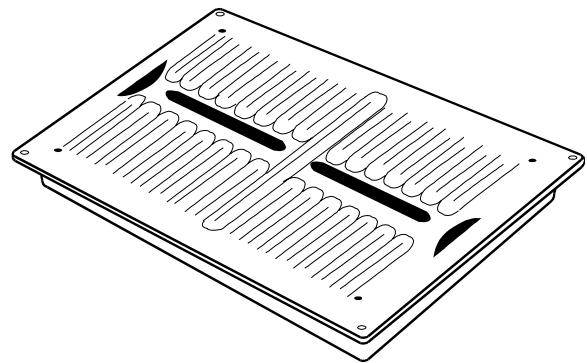

Broiling Pan and Grille

Removal of Main Oven Door

At times you may want to remove the oven door for thorough cleaning of the oven. Removal of the oven door is easy:

- 1) Open oven door, and latch the brass catches on to the upper leg of the hinge. (see below). Make sure the catch is **securely** hinged.
- 2) With a hand on each side of the door lift the door slightly, and pull out.
- 3) The door weighs about 17 LBS (8 kg) , so exercise caution when removing the door.
- 4) To replace the door reverse this sequence.

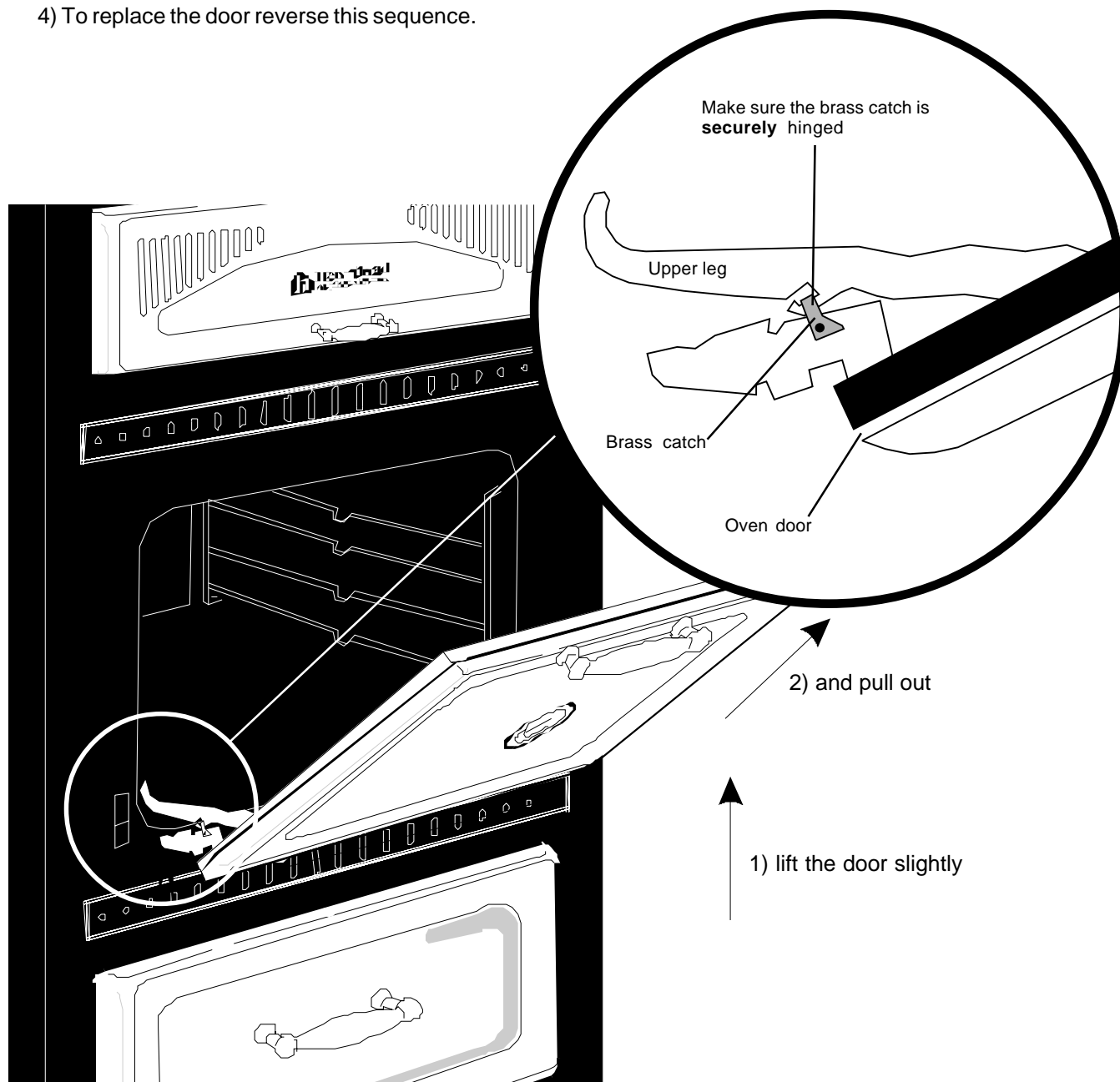

WARNING!

Do not sit, lean, lift or stand on the doors or drawers of this range as possible injuries may result.



Removal of Lower Oven Door

At times you may wish to remove one or both oven doors for thorough cleaning of the oven. Removal of the lower oven door is easy:

- 1) Open oven door and remove the two screws directly in line with the hinges about half way up the panel.
- 2) Close the door about 2/3 of the way.

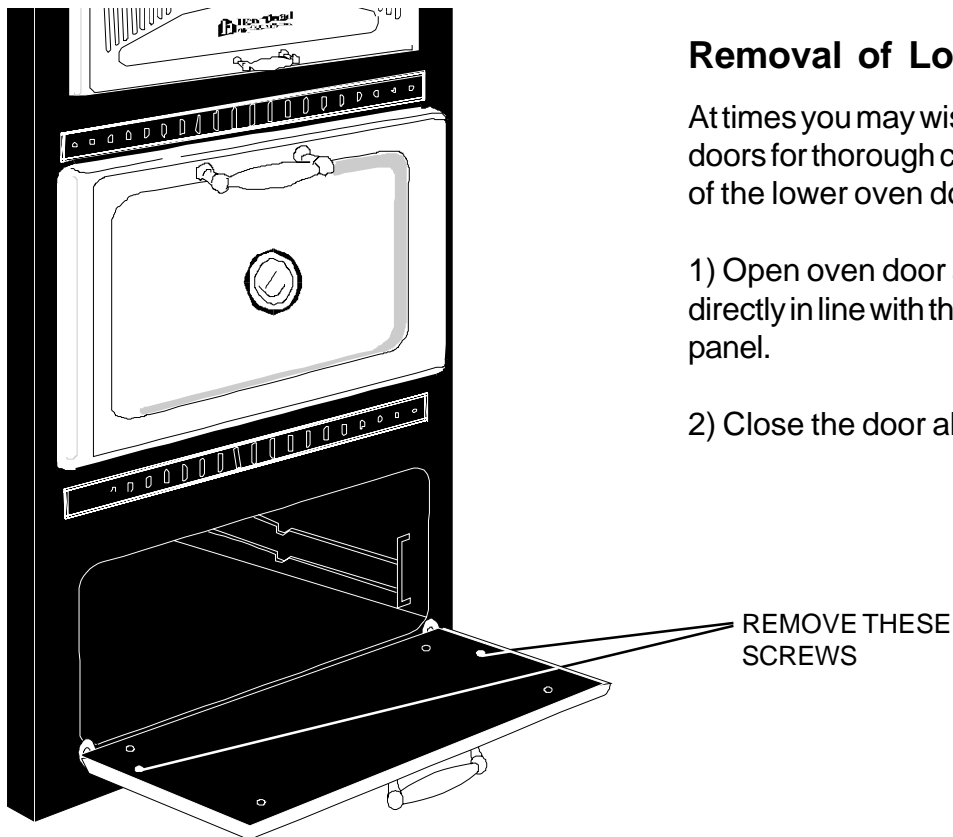

REMOVE THESE SCREWS

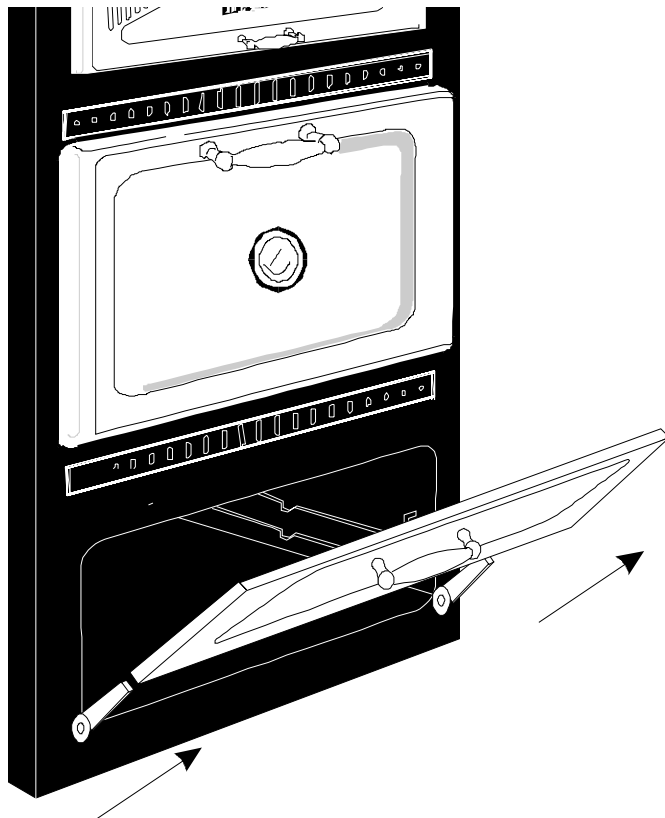

3) Grasping on each side of the door pull up slow and steady.

4) The spring loaded hinge locks will swing into position and "lock" the hinges to an open position as the door is being removed.

5) To replace the door reverse this sequence. Be careful not to overtighten the screws as this may cause the porcelain to crack or shatter.

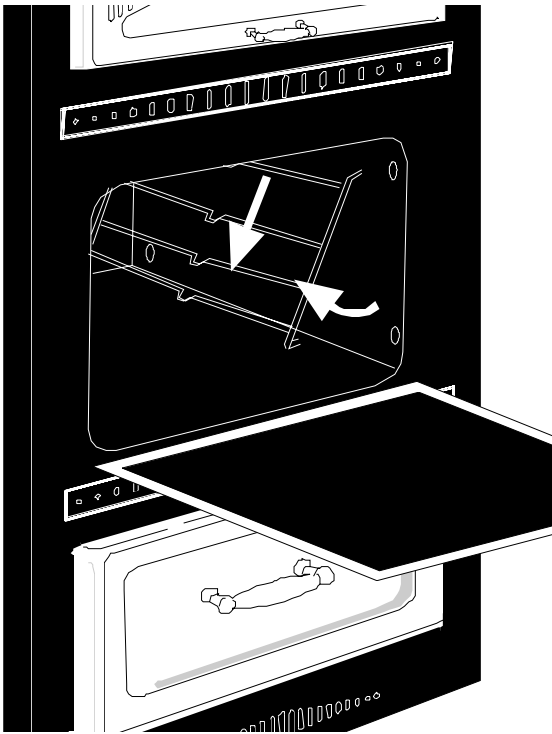

Rack Supports

The oven rack supports are designed to interlock into the oven sides but are easy to remove. First remove oven racks, then grasping the lower portion of the rack support, swing it out to approx. 45 degrees and gently pull down. Assemble in reverse order.

Interior Oven Rack

The oven rack is designed with stop-locks so that when placed correctly on the supports, it (a) will stop before coming completely out of the oven, (b) will not tip when placing or removing food.

To install, place the rack "feet" on the rack support and push the oven rack backward along the rack support (see ①).

Push the oven rack all the way to the back until the oven rack slips off the end of the rack support (see ②).

Then pull rack support ahead slightly to engage the "feet" with the rack support (see ③). To remove reverse removal procedure.

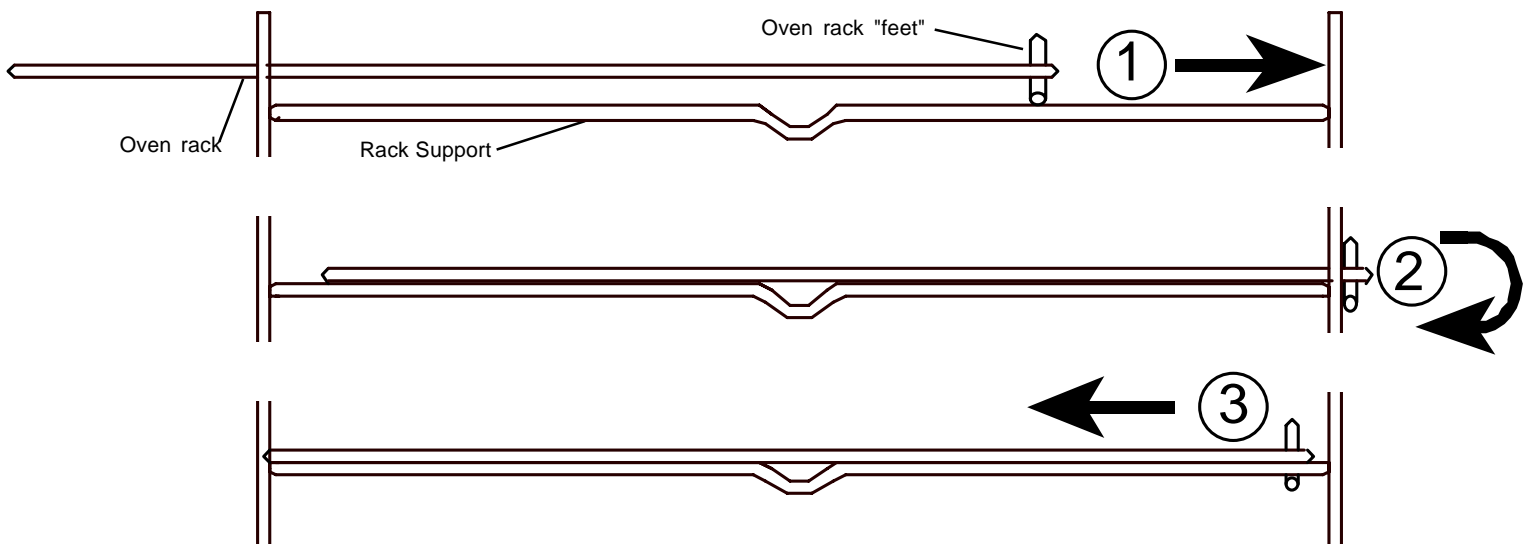

Problem Solver

To save time and money before you call for service, check this guide.

If you have a problem it may be minor. You may be able to correct it yourself. Use this Guide to locate your problem and then follow the suggested recommendation.

Oven will not work

- The circuit breaker has been tripped or a fuse is blown in your house at the switch panel.
- The timer is not set, if the timer is flashing see page 12 "Time of Day Setting"
- The timer is set for time bake. If "AUTO" is lit, then time bake function is on. Push the cancel "" button
- The self clean high limit breaker has activated, The high limit breaker is located on the control panel above the self clean rocker switch. Reset by pushing in the red plunger.

Food does not broil properly

- Broil control not set properly
- Rack position is incorrect.
- Necessary preheating was not done.
- Utensils are not suited for broiling.

Food is not roasting properly

- Oven temperature is not set correctly.
- Rack position is incorrect.
- Roasting pan is too small.
- Improper cookware is being used.
- A foil tent was not used when needed to slow down browning.

Food is not baking properly

- Control is not set properly.
- Rack is not on correct shelf position.
- The wrong cookware is being used.
- Too many utensils in the oven.
- Temperature setting is incorrect.

Oven light does not work

- Check that light switch is not jammed.
- Light bulb is loose.
- Bulb has blown.
- Breaker or fuse has been tripped or blown.

Lower oven does not function

- Lower oven is disabled during self clean mode of main oven
- The circuit breaker has been tripped or a fuse is blown in your house at the switch panel.

Oven Thermostat

Oven thermostats, in time, may "drift" from the factory setting and differences in timing between an old and new oven of 5 to 10 minutes are not unusual.

Your oven control has been set at the factory and is more apt to be accurate than the oven which it replaced.

Voltage lower than 240v will affect performance, particularly preheat time, which increases from 10-12 minutes to 20 - 22 minutes.

If you still require help...

Heartland Ranges contain standard electrical components available from your dealer or Heartland Appliance Inc.

In case repair is required, consult your Dealer for an appliance repair depot near you. For warranty service, please call your dealer, or call Heartland:

Bus. (519) 650-5775 or Fax (519) 650-3773

Toll Free Phone 1-800-361-1517

Toll Free Fax 1-800-327-5609

Have your **serial number**, **model**, and **date of purchase** information ready.

Model 9730 Parts Chart

TO ENSURE THE CORRECT COLOR MATCH WHEN ORDERING COLORED PANELS, BOTH THE COLOR AND SERIAL NUMBER MUST BE PROVIDED.

Please order part by number. Parts may be ordered from your dealer or direct from Heartland Appliances Inc. Telephone for prices and ordering instruction. Call 519-650-5775 and ask for the order desk.

- | | | | |
|-------|--|-------|--|
| 1110 | Oven Door Handle Stanchion | 91051 | Drawer - Front Panel (serial number required) |
| 11201 | Outer Oven Door Panel (serial number required) | 9108 | Small Door Frame |
| 1125 | Oven Door Thermometer (Non Functional) | 9110 | Upper Heat Shield |
| 6163 | Bake/Broil Knob (upper oven) | 9111 | Lower Heat Shield |
| 6171 | Indicator Light - Orange | 9120 | Self Clean Upper Hear Shield |
| 6198 | On / Off Rocker Switch | 9146 | Oven Door Gasket-half Oven |
| 6163 | Broil / Bake Knob | 9141 | Oven Door Frame Weldment |
| 6202 | Oven Light Bulb - 40w | 9163 | Bake/Broil Knob (lower oven) |
| 6347 | Oven/Broiler Control Switch | 9221 | Control Door Weldment |
| 6359 | Self Clean Oven/Broiler Control Switch | 9224 | Control Cover Accent Panel |
| 6382 | Self Clean High Limit 1 Pole | 9234 | Self Clean/Non Self Clean Electronic Timer (Diehl) |
| 6384 | Self Clean Rocker Switch | 60307 | Broiler Element (3000w) |
| 6387 | Self Clean Oven Door Gasket | 9240 | Buried Bake Element (1000w) |
| 6388 | Knob For Self Clean Door Lock | 60308 | Oven Element (3000w) |
| 6397 | Oven Door Handle | 9250 | Mini Stantion |
| 6437 | Oven Door Hinges L & R (not shown) | 9254 | Control Door Handle |
| 6455 | Broiler Pan & Cover | 9449 | Oven Rack Support (4 position) |
| 9716 | Installation and Operating Instruction Manual | 9452 | Oven Rack |
| 8200 | Light Socket & Housing | | |
| 8202 | Light Socket Assembly | | |
| 8204 | Oven Lens | | |
| 9019 | Convection Filter W/Clips | | |

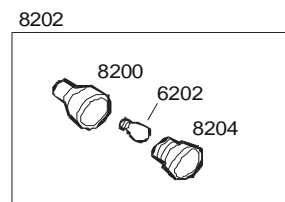
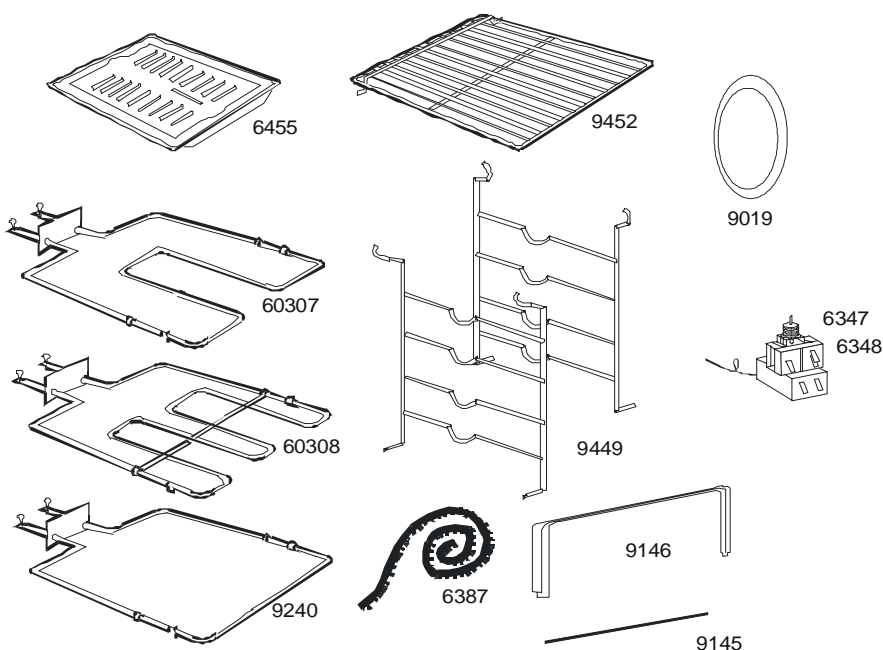
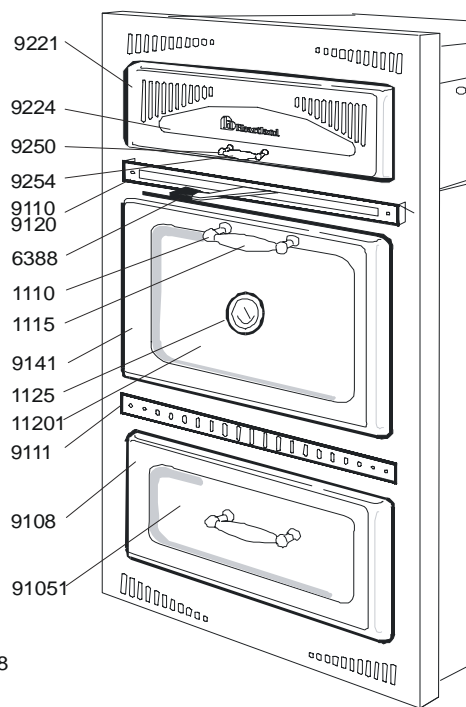
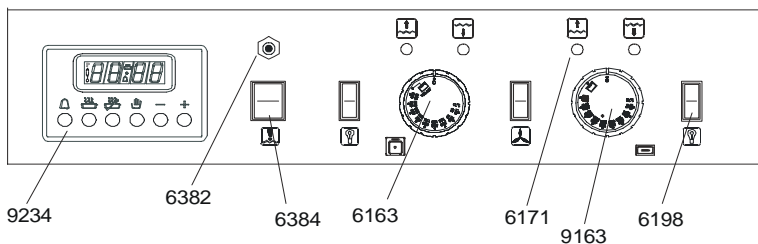

Wiring Diagrams

Technical Data for model 9730

- Voltage 240 V/ 60 Hz North America
- Load 6.3 kW

NOTE: Service amperage should be calculated by a qualified electrician.

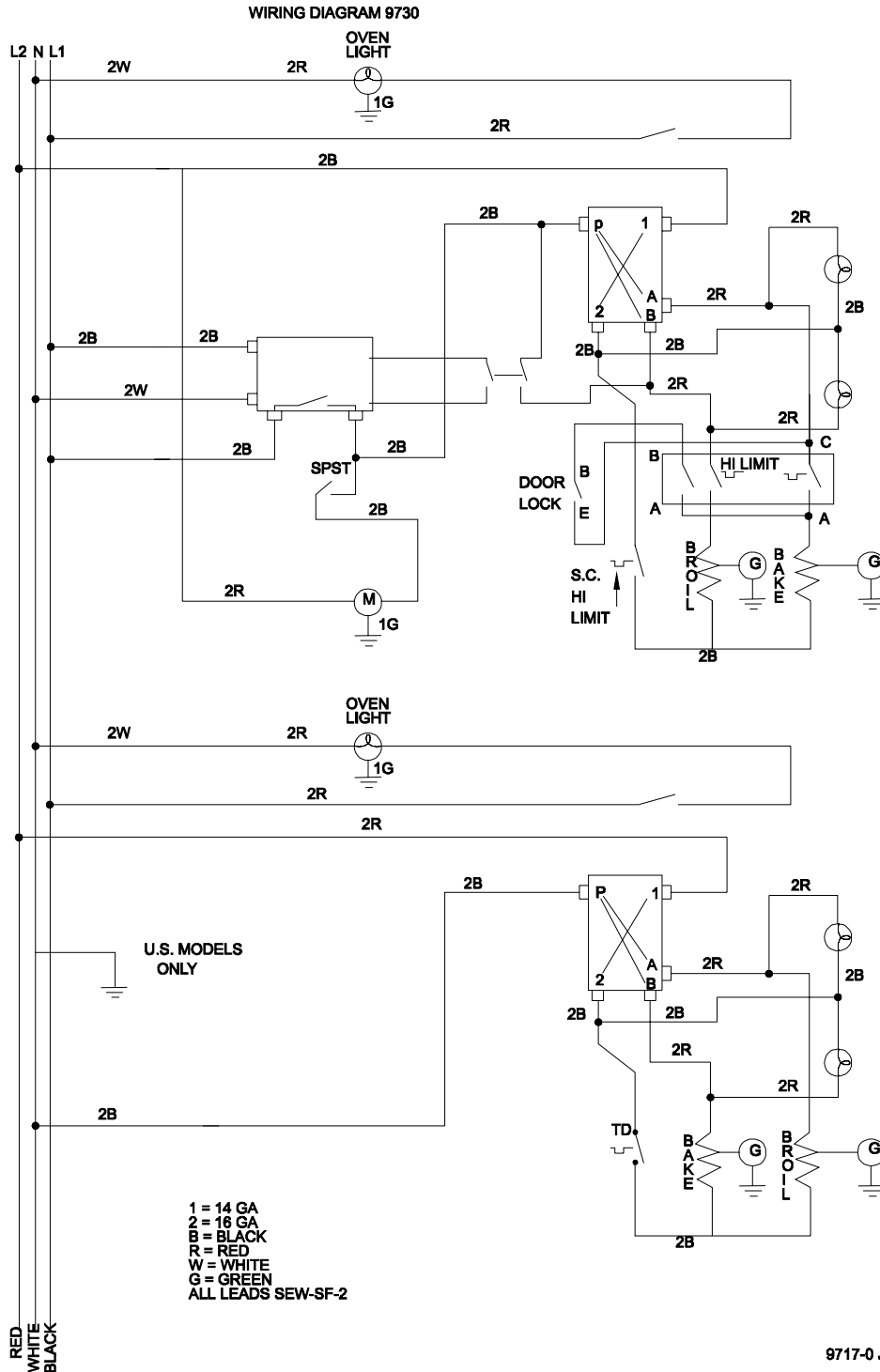

See our complete line of kitchen appliances:

3010- 30" Classic II Series Refrigerator, 18 cubic feet capacity, bottom mount freezer drawer, and convenient top mount fresh food compartment. Ice maker is available as an option. The Classic series also offers an optional Cowl. Energy efficiency rating 548 kwh/year. Also available in Metro **3220** and Legacy **3060** models.

3115- 36" Classic Series Refrigerator, 20 cubic feet capacity, bottom mount freezer, counter depth design. Ice maker is standard. The Classic series also offers an optional Cowl. Energy efficiency rating 481 kwh/year. Also available in Metro **3315** and Legacy **3165** models.

3530- Legacy Gas / Electric kitchen range - 4 sealed gas burners, electric convection oven fits in a 30" opening! Also available in stainless steel as model **3535** Metro. Cooktop versions for both Metro 3805 and Legacy **3800** models are available.

3630- Legacy 36" Gas / Electric kitchen range - 6 sealed gas burners or 4 sealed burners and centre grill! Electric convection oven come standard. Also available in stainless steel as model **3635** Metro. Cooktop versions for both Metro **3825** and Legacy **3820** models are available.

9730 (Built-in)- Dual oven, one convection, one standard radiant, with *self clean oven feature*.

4210- 30" Gas / Electric kitchen range - 4 sealed gas burners, electric convection self clean oven fits in a 30" opening!

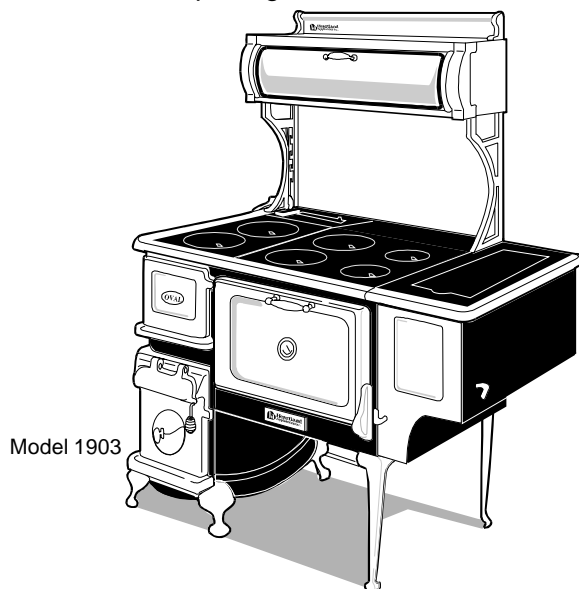

Model 1903

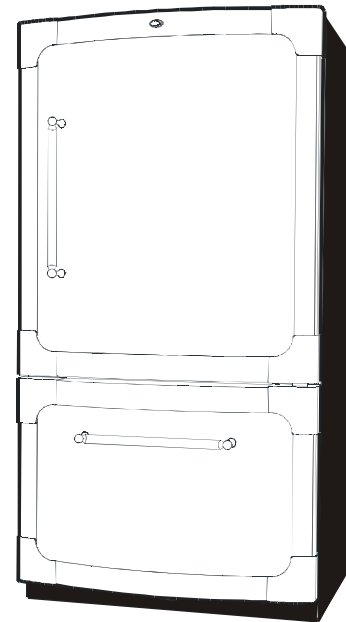

Model 3115:
Classic Series

5210- 48" Gas / Electric kitchen range- 6 sealed gas burners, electric convection self clean oven, dual fuel!

6210- 48" Electric kitchen range - 5 radiant burners under Eurokera Ceramic cooktop, convection self clean oven .

8210-30" Electric kitchen range - 4 radiant burners under Eurokera Ceramic cooktop, convection self clean oven, fits in a 30" opening!

7100- 48" Gas or propane kitchen range - 6 sealed gas burners, a chef's dream come true!

9100- 30" Gas or propane kitchen range - 4 sealed gas burners, fits in a 30" opening!

1900 (Oval)- Wood burning cookstove-old fashioned cooking available in two models

2600 (SweetHeart)- Wood burning cookstove-same as the Oval, in a smaller version!

For more information please call your dealer, or call Heartland Appliances:
Phone 1-800-361-1517 or Fax 1-800-327-5609