

# Dakota™ – The world's first outdoor gas fireplace

## DAKOTA...ALL GAS, RUGGED AND DESIGNED FOR THE GREAT OUTDOORS

The Heat-N-Glo® story of innovation continues with Dakota, the world's first gas fireplace developed specifically for outdoor use. Dakota delivers all the convenience, efficiency and ambiance of a gas fireplace in the beauty of an outdoor setting!

### Product Specifications:

- Complete gas fireplace system—LP or Natural
- Smoke-free, no messy ashes
- Durable and sleek stainless steel construction for outdoor use
- Realistic concrete logs and refractory are completely weatherproof
- Equipped with a safety pilot ignition system
- Vents through decorative front grille—eliminating any need for a chimney
- Chimney-free construction won't obstruct views
- Standard glass doors provide added control in windy conditions
- Approved for use in screened porches, gazebos and lanais
- Designed to fit into LifeStyle Collection *Fireplace Surround Builder Sets*
- UL listed
- 52,000 BTUs/hr with LP Gas
- 61,000 BTUs/hr with Natural Gas
- Patented technology
- 15 year limited warranty



DAKOTA STAINLESS STEEL FIREPLACE SHOWN WITH OPTIONAL CUSTOM-FINISHED DAKOTA FIREPLACE SURROUND BUILDER SET

# Dakota™ – Specification Information



MODEL	HEIGHT	WIDTH	DEPTH
Dakota Fireplace-See framing dimensions below	-	-	-
Dakota Surround Builder Set (optional)	47-1/2"	60"	30"
FRAMING DIMENSIONS	HEIGHT	WIDTH	DEPTH
Using combustible material (with clearances)	43-3/4"	49"	24-3/4"
Using non-combustible material (no clearances)	37-3/8"	48-1/4"	23-1/4"

## GAS VALVE BOX ASSEMBLY

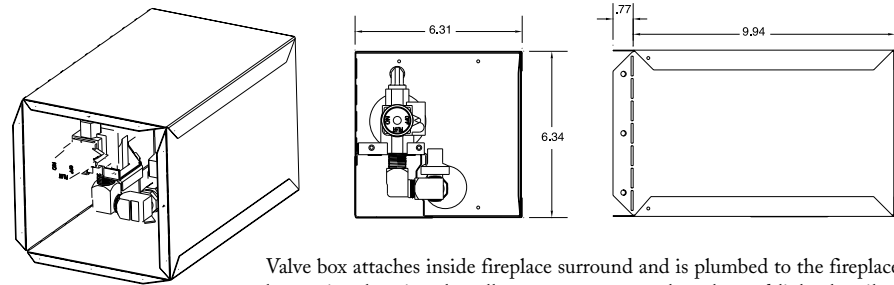

Valve box attaches inside fireplace surround and is plumbed to the fireplace burner in a location that allows one to operate the valve and light the pilot.

TOP

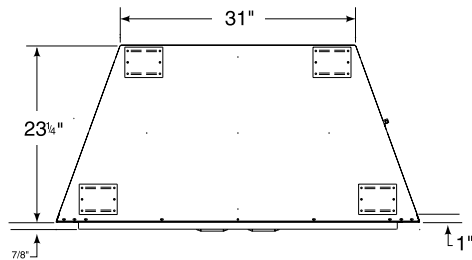

LEFT SIDE

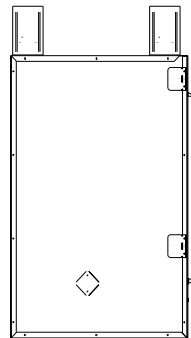

FRONT

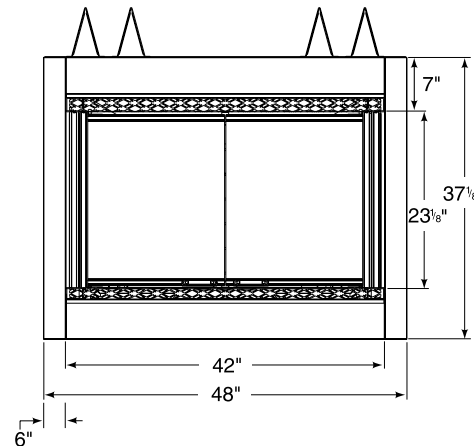

RIGHT SIDE

